

LIETOTĀJA ROKASGRĀMATA

WOODRIDGE PRO

LAIPNI LŪGTI KOKSNES-KURINĀMĀ REVOLŪCIJĀ

Mēs vēlamies, lai jūs gūtu maksimumu no sava Traeger.

SVARĪGS PAZIŅOJUMS / IMPORTANT NOTICE

Šis tulkojums tiek sniegts tikai kā pakalpojums. Produktam pievienotā oriģinālā angļu valodas lietotāja rokasgrāmata ir juridiski saistošs dokuments. Jebkādu neatbilstību gadījumā noteicošā ir angļu valodas versija.

This translation is provided as a courtesy service only. The original English manual included with the product is the legally binding document. In case of any discrepancy, the English version shall prevail.

JURIDISKS PAZIŅOJUMS UN TULKOJUMS

Šis dokuments ir latviešu valodas tulkojums, ko sniedz Traeger Pellet Grills Europe ApS tikai kā pakalpojumu, lai padarītu lietotāja rokasgrāmatu pieejamāku latviešu valodā runājošiem lietotājiem.

Produktam fiziski pievienotā angļu valodas oriģinālā rokasgrāmata ir vienīgais juridiski saistošais dokuments. Jebkādu neatbilstību gadījumā starp šo tulkojumu un oriģinālo dokumentu vienmēr ir noteicošā angļu valodas versija.

Šis tulkojums neaizstāj oriģinālo rokasgrāmatu. Pirms Traeger Woodridge grila uzstādīšanas, montāžas vai lietošanas pilnībā izlasiet oriģinālo angļu valodas rokasgrāmatu.

Attēli, tehniskās diagrammas un grafiskās atsauces nav mainītas no oriģinālā dokumenta; ilustrācijās iekļautie teksti paliek angļu valodā.

Tehniskā atbalsta, garantijas vai klientu apkalpošanas jautājumos skatiet kontaktinformāciju šī dokumenta beigās vai apmeklējiet support.traeger.com.

ENGLISH NOTICE

This document is a Latvian translation provided by Traeger Pellet Grills Europe ApS solely as a courtesy service. The original English manual is the only legally binding document.

SVARĪGI DROŠĪBAS NORĀDĪJUMI

IZLASIET VISUS NORĀDĪJUMUS PIRMS TRAEGER GRILA UZSTĀDĪŠANAS UN LIETOŠANAS

DROŠĪBAS BRĪDINĀJUMU ATSLĒGA

BĪSTAMI

Norāda uz tiešu bīstamu situāciju, kas — ja netiek novērsta — izraisīs nāvi vai nopietnu traumu.

BRĪDINĀJUMS

Norāda uz nopietnu miesas bojājumu vai nāves iespēju, ja norādījumi netiek ievēroti.

UZMANĪBU

Norāda uz potenciāli bīstamu situāciju, kas — ja netiek novērsta — var izraisīt nelielu vai vidēju traumu.

GALVENAIS UGUNSGRĒKU CĒLONIS IR NEPIECIEŠAMO ATTĀLUMU (GAISA TELPAS) NEIEVĒROŠANA STARP VIEGLI UZLIESMOJOŠIEM MATERIĀLIEM UN GRILU. IR ĀRKĀRTĪGI SVARĪGI, LAI ŠIS PRODUKTS TIKTU UZSTĀDĪTS TIKAI SASKAŅĀ AR ŠIEM NORĀDĪJUMIEM.

Pareizi lietojot un apkopjot, gatavošana ar koka uguni uz Traeger grila sniedz daudzus gadus prieka jums, ģimenei un draugiem. Jūsu jaunais Traeger grils ir īpaši izstrādāts, lai gatavošanu padarītu vieglāku, vienlaikus piedāvājot optimālu sniegumu ar visgaršīgāko ēdienu.

Pirms uzstādīšanas un lietošanas izlasiet visu šo rokasgrāmatu. Visiem, kas izmanto šo grilu, pirms tā lietošanas jāizlasa visa rokasgrāmata. Šo norādījumu neievērošana var izraisīt materiālus zaudējumus, miesas bojājumus vai pat nāvi. Sazinieties ar vietējām būvniecības vai ugunsdrošības iestādēm par ierobežojumiem un uzstādīšanas pārbaudes prasībām. Saglabājiet šos norādījumus.

BĪSTAMI — Oglekļa monoksīda risks

Koka granulu sadedzināšana rada oglekļa monoksīdu (CO), kas var izraisīt slimību, nopietnu traumu un/vai nāvi. Ievērojiet šos norādījumus, lai šī bezkrāsainā un bez smaržas gāze neievainotu jūs, ģimeni, mājdzīvniekus vai citus:

- Lietojiet Traeger grilu tikai ārpus telpām labi vēdināmā vietā. Grils ir paredzēts TIKAI ĀRA LIETOŠANAI.
- Nekad nelietojiet Traeger grilu slēgtā telpā vai telpā bez pietiekamas ventilācijas.
- Pārziniet oglekļa monoksīda saindēšanās simptomus: galvassāpes, reibonis, vājums, slikta dūša, vemšana, miegainība un apjukums. Oglekļa monoksīds samazina asiņu spēju transportēt skābekli.
- Vērsieties pie ārsta, ja jums vai citiem rodas saaukstēšanās vai gripas simptomi gatavošanas laikā vai šī ierīces tuvumā.
- Alkohola lietošana un narkotiku lietošana palielina oglekļa monoksīda saindēšanās ietekmi.
- Oglekļa monoksīds ir īpaši toksisks mātei un bērnam grūtniecības laikā, zīdaiņiem, gadus vecākiem cilvēkiem, smēķētājiem un cilvēkiem ar asiņu vai asinsrites problēmām.

BRĪDINĀJUMS — Aizdeģšanās risks

- Lietojot Traeger grilu, saglabājiet MINIMĀLI 50,8 cm (20 collu) attālumu starp grilu un viegli uzliesmojošiem materiāliem, ieskaitot koka margas, ēku apdari, logu rāmjus, mēbeles, kokus, atkritumu konteinerus utt.
- Neuzstādi un nelietojiet šo grilu telpās vai zem uzliesmojošas griestiem vai jumta izvirzījuma.

- Neuzstādiet un nelietojiet Traeger grilu uz uzliesmojošām grīdām vai virsmām.
- Nelieciet grila pārklāju vai jebko viegli uzliesmojošu uzglabāšanas vietā zem grila.
- Lai samazinātu aizdegšanās risku, izņemiet katlus un pannas no ierīces, kad tā darbojas bez uzraudzības.

BRĪDINĀJUMS — Elektrošoka risks

Klāt ir bīstams spriegums, kas var izraisīt elektrošoku, apdegumus vai nāvi.

- Šim Traeger grilam izmantojamām ķēdēm vai kontaktligzdām jāuzstāda noplūdstrāvas slēdzis (GFCI).
- Pirms apkopes atvienojiet strāvas vadu, ja vien šajā rokasgrāmatā nav norādīts citādi.
- Ja izmantojat pagarinātāju, izmantojiet tikai pagarinātāju, kas piemērots āra lietošanai, lai novērstu elektriskos triecienus.
- Izmantojiet No. 18 AWG pagarinātāju.
- Nemodificējiet Traeger grila spraudni vai pagarinātāja kontaktligzdu nekādā veidā.
- Pārlicinieties, ka pagarinātājs ir labā stāvoklī pirms katras lietošanas.
- Nesavienojiet pagarinātājus savā starpā.
- Turiet pagarinātāju prom no sniega un stāvoša ūdens.

SAGLABĀJIET ŠOS NORĀDĪJUMUS

SATURA RĀDĪTĀJS

Svarīgi drošības norādījumi	2
Garša ir svarīga	8
Iepazīstieties ar savu grilu	10
Ātrās atsauces ceļvedis	13
Pirmie soļi	14
Onboarding – 1. daļa: Pievienojiet grilu	14
Onboarding – 2. daļa: Grila iesildīšana	16
Ikdienas Traegerēšana	19
Grila izslēgšana	22
Grila papildu funkciju lietošana	23
Granulu tvertnes iztukšošana	33
Grila apkope	34
Problēmu novēršana	36
Darbības padomi	37
Apkalpošana	37
Garantija	38

IEPAZĪSTIETIES AR SAVU GRILU

Grila grilēšanas laukums: 0.63 m² (970 in²)

Granulu tvertne: 11 kg (24 lb)

TRAEGER GRILA GARANTIJA

IEROBEŽOTA 10 GADU GARANTIJA

Traeger Pellet Grills Europe ApS, Kattegotvej 40, 2150 Kopenhāgena, Dānija, („Traeger“) garantē šo Traeger grilu attiecībā uz komponentiem, segumu un garantijas periodiem, kas norādīti zemāk esošajā tabulā, normālas lietošanas un pareizas apkopes apstākļos. Šī garantija tiek sniegta papildus jūsu kā pircēja tiesībām saskaņā ar jūsu dzīvesvietas valsts likumiem un neatņem jums aizsardzību, ko sniedz šie likumi. Attiecīgais garantijas periods sākas no oriģinālā pirkuma līguma noslēgšanas datuma ar Traeger pilnvarotu pārdevēju un tiek piešķirts klientiem Eiropā.

Komponents	Periods	Segums
Korpuss, klijas un granulu tvertnes vāks	10 gadi	Neierīks cauri
Kontrolieris, skrīves motors, skrīve un ventilators	3 gadi	Materiāla un ražošanas defekti
Pilienu paliktnis, ogļu aizsargs un karstuma gaiss kolektors	3 gadi	Materiāla un ražošanas defekti
Emaljēti grila režģi	3 gadi	Neierīks cauri
Sildvarbas, vads, RTD un termopāris	1 gads	Materiāla un ražošanas defekti
Gaļas zondes un bezvadu gaļas zondes	1 gads	Neierīks cauri

Šo garantiju reglamentē Dānijas likumi. Šī tiesību izvēle neatņem jums aizsardzību, ko sniedz jūsu dzīvesvietas valsts likumi.

Traeger kopējā atbildība un jūsu vienīgais līdzeklis ir Traeger grila bojāto detaļu nomaiņa. Oriģinālās detaļas, kuras Traeger klientu apkalpošana ir apstiprinājusi atgriešanai, jāatgriež ar iepriekš samaksātu sūtīšanu. Traeger var aizstāt bojātās detaļas ar jaunām vai atjaunotām detaļām pēc saviem ieskatiem.

Šī garantija ir spēkā neesoša, ja: (i) grils netiek samontēts vai lietots saskaņā ar Traeger lietošanas norādījumiem; (ii) grils nav iegādāts no pilnvarota pārdevēja; (iii) grils tiek pārdots tālāk; (iv) ir izmantoti citi degvielas materiāli, nevis koka granulas, kas paredzētas koka granulu griliem; (v) ir izmantotas apkures granulas; (vi) grils ir lietots komerciāli vai pārtikas apkalpošanas vajadzībām; (vii) lietotājs ir pieļāvis bojājumu, ļaunprātīgu izmantošanu vai nav uzturējis grilu; vai (viii) grils ir neatļauti modificēts.

Lai apstrādātu garantijas pieprasījumu, sazinieties ar Traeger klientu apkalpošanu pa tālruņa numuru vai uz iepriekš norādīto adresi. Traeger pieprasa pierādījumu par jūsu pirkuma datumu no pilnvarota pārdevēja.

APKALPOŠANA

TRAEGER LEĢENDĀRĀ KLIENTU APKALPOŠANA ir labākā, kas pastāv. Ja jums ir jautājumi par savu Traeger grilu, mūsu pieredzējušie eksperti ir jūsu rīcībā 365 dienas gadā.

Tālrunis (starptautisks):	traeger.com/support/international-contact-info
Tīmekļa vietne:	support.traeger.com
Adrese:	Traeger Pellet Grills Europe ApS — Kattegatvej 40, 2150 Kopenhāgena, Dānija

GETTING TO KNOW YOUR GRILL

Refer to the Assembly Guide to assemble your Traeger Woodridge Grill.

PARTS AND FEATURES



PART	DESCRIPTION	PART	DESCRIPTION
1	UPPER GRILL GRATE	11	LEGS
2	LOWER GRILL GRATE	12	CASTERS
3	MODIFIRE GRILL GRATE	13	BOTTOM SHELF
4	DRIP TRAY	14	P.A.L. POP-AND-LOCK ACCESSORY RAILS
5	HEAT BAFFLE	15	LID HANDLE
6	GREASE DRAIN CHUTE	16	LID
7	EZ-CLEAN GREASE & ASH KEG	17	WiFi FIRE CONTROLLER
8	EMBER SHIELD	18	AUGER BOX
9	WIRED MEAT PROBE	19	ALL-TERRAIN WHEELS
10	FOLDING SIDE SHELF		

WEIGHT CAPACITY

Hopper: 11 kg (24 lbs)

Folding Side Shelf: 23 kg (50 lbs)

Bottom Shelf: 27 kg (60 lbs)



PELLET HOPPER

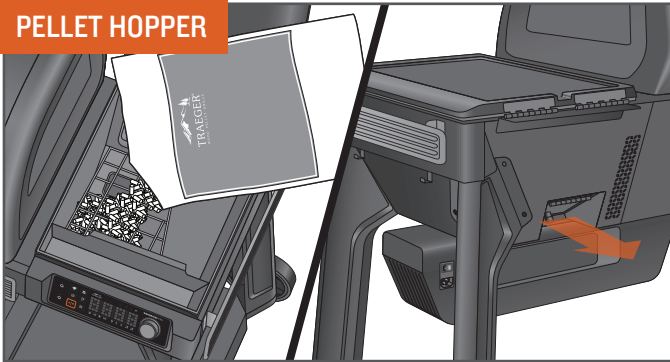

The hopper's 11 kg (24 lb) capacity allows for hours of cooking with no need to refill. Pellets can be emptied through the pellet release door on the back by unscrewing the knob.

USE ONLY TRAEGER HARDWOOD PELLETS. This product is developed and tuned using only Traeger pellets. Traeger pellets are crafted to meet strict quality and performance standards. Using pellets not manufactured by Traeger may result in inconsistent performance, poor flavour, and temperature inconsistency.

GRILL SHAPE

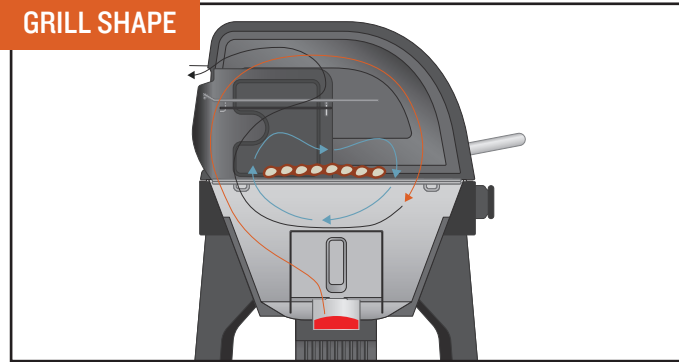

Your Traeger Woodridge Grill has a unique barrel shape that helps funnel the smoke in and around your food for better, more flavourful results.

GRILLING SPACE

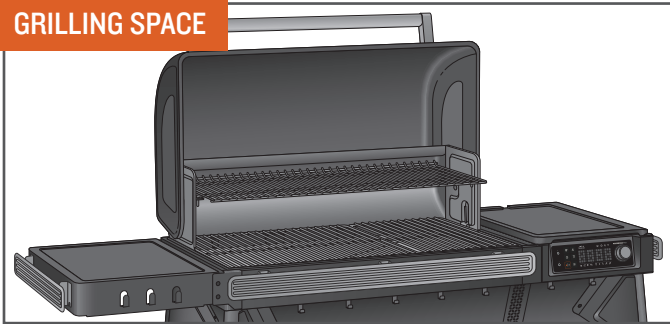

With 0.63 m² (970 in.²) of grilling space, your Traeger Woodridge Grill has the real estate for party-sized orders of T-bones or racks of ribs, with enough room left over to handle those side dishes, too.

WiFi CONNECTIVITY



Download the Traeger App and connect your grill to unlock the power of Traeger's WiFIRE Technology. With the Traeger App you can remotely control your grill from anywhere, and your grill will also receive the latest and greatest firmware updates, keeping your grill operating at peak performance. See "Onboarding Part I: Connecting Your Grill" (page 14) for instructions on how to connect your grill to your phone.

VERSATILITY

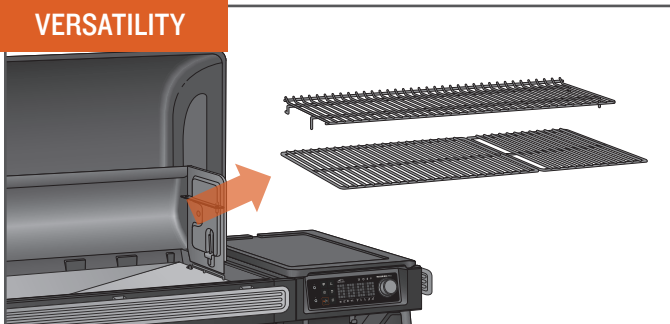

A removable upper grill grate and the lower Modifire grill grate offer you the versatility you need to cook anything.



PRO TIP: The upper grate can be stored on back of the grill when cooking large items like turkeys (see page 34 for more information).

NO FLARE-UPS

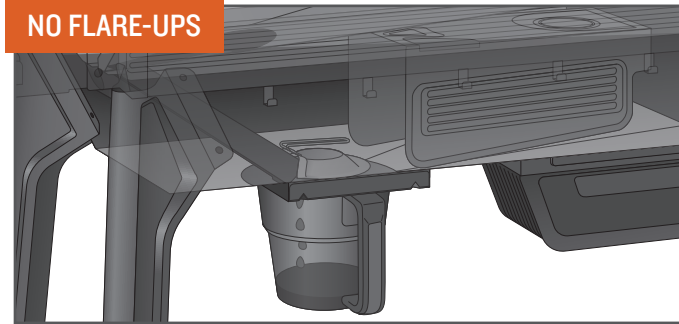

All grease is safely channelled into the EZ-Clean Grease & Ash Keg for disposal. This, combined with regular maintenance, prevents flare-ups and nasty fireballs from destroying your food.



PRO TIP: Keep your grill clean. See "Operating Tips" (page 37) and "Maintaining Your Grill" (page 34).



GETTING TO KNOW YOUR GRILL CONTINUED

YOUR WIFIRE DIGITAL CONTROLLER

Your Traeger Woodridge Grill is equipped with a state-of-the-art Traeger Controller with WiFIRE technology that is Wi-Fi-capable and Bluetooth-enabled. Before you begin using the grill, familiarise yourself with the different features of the controller. Once the main power switch (located on the back side of the auger box) is ON (I), tap the ignite/shutdown button or turn the selection dial to wake the controller from sleep.

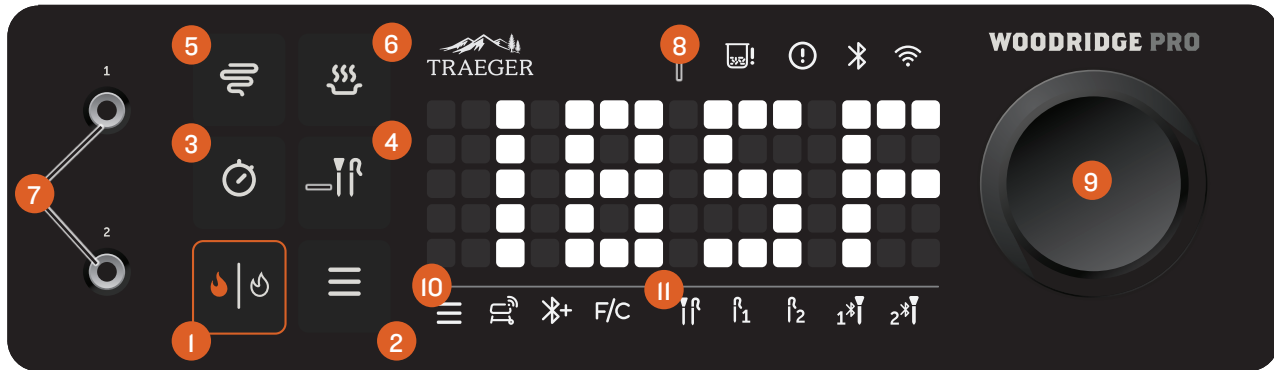

PRO TIP: On a good weather day, it is completely normal for a Traeger Grill to experience temperature fluctuations of +/- 25°F (+/- 14°C). These fluctuations are actually a key component in creating the smoke flavour we at Traeger love. Your Traeger Grill is designed to manage these fluctuations on its own. No need to change the set temperature! Any significant fluctuation could be the result of wind, air temperature, improper use, lack of grill maintenance, or opening the lid too often.

1 IGNITE/SHUTDOWN

Use this button to ignite your grill. If your grill is already running, press and hold this button to initiate a shutdown cycle.

2 MENU

You can connect your grill to WiFIRE, connect your Traeger wireless meat thermometer, and change temperature units from this menu.

3 TIMER

The timer is for your convenience only; it does not affect grill operation. For example, if you need to braise your meat for 15 minutes, set the timer for 15 minutes. A tone will sound when the time is up.

4 PROBES

After connecting any wired probes via probe jacks or any Traeger wireless meat thermometers via the menu button, tap this button to interact with the connected probes. After tapping this probe button, use the selection dial to toggle between connected probes. When your desired probe lights up in the probe menu bar, press the dial to set/modify a probe goal alert for when a probe has reached the desired internal temperature.

5 SUPER SMOKE

Use this button to add more smoke flavour to your food.

NOTE: Only available when your grill is set to 225°F (107°C) or lower.

6 KEEP WARM

Use this button to pause the cook cycle at any time during grilling and maintain the grill at a low temperature.

7 WIRED PROBE JACKS

Use these jacks to plug in wired temperature probes.

8 STATUS DISPLAY

This dot matrix display shows current grill temperature, status of cook cycle, and all things related to grill control and function.

9 SELECTION DIAL

Rotate this dial to move up and down through the displayed menu. Press the centre of the dial to make a selection.

10 MENU BAR

The menu bar icons light up when you tap the menu button to indicate which setting you are editing. Turn the selection dial to cycle through these selections.



Grill Connectivity Icon: Lights up when you are adjusting the WiFIRE setting on your grill.



Add Bluetooth Accessory Icon: Lights up when you are pairing Bluetooth accessories.



F/C Icon: Lights up when you are adjusting your grill's temperature to Fahrenheit or Celsius.

II PROBE MENU BAR



The probe menu bar icons will light up as wired or Traeger wireless meat thermometers are connected, disconnected, selected, and activated for goal alerts. You can connect two wired probes and two Traeger wireless meat thermometers. Tap the probe button (middle right button to the left of the status display) to highlight connected probes in this probe menu one at a time. Use the selection dial to toggle between probes and press the dial to set/modify a probe goal alert for an individual probe. See the key below for probe states:

Off: Indicates that this wired probe or Traeger wireless meat thermometer is not connected.

Dim: Indicates that this wired probe or Traeger wireless meat thermometer is connected but not actively selected.

On: Icons will light up to full brightness when you tap the probe button. After tapping the button, turn the selection dial to see the selected probe icon turn to full brightness.

Blue: A probe icon will turn blue when a probe goal alarm has been set.

Blue + flashing: A probe icon will flash blue when a probe goal has been reached.

ONBOARDING PART 2: SEASONING YOUR GRILL



PRO TIP: Seasoning must be completed before cooking food on your grill. For more information, scan here to access the Seasoning Guide.



Before you can cook on your grill, the grill must be seasoned. This is a hands-off process in which the empty grill gets heated to a very high temperature. This seasoning cycle ensures the grill is cleaned of any factory residue, primed, and ready for optimal performance.

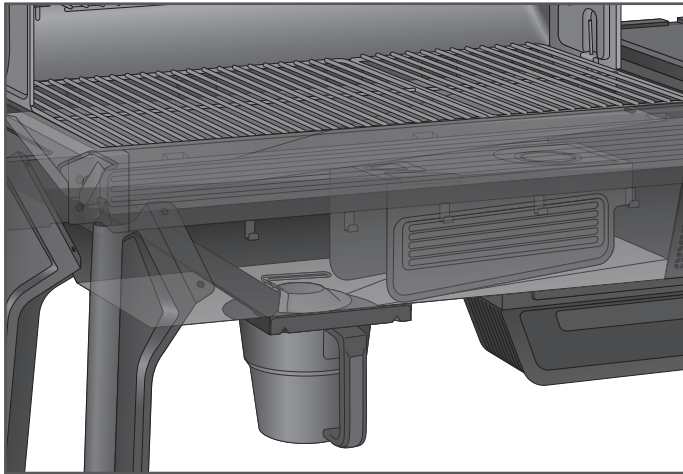

IMPORTANT:

- Make sure all components are properly installed in the grill and that all packaging/shipping materials are removed prior to seasoning.
- Do not wipe protective grease coating off of components before seasoning. This coating provides a more durable burn-in protective layer.

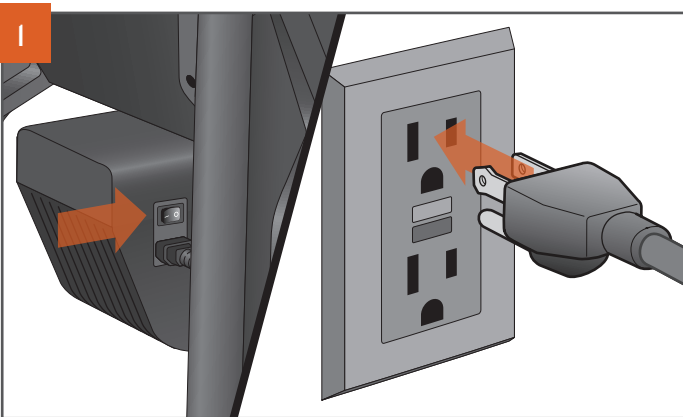

With the main power switch set to OFF (0), connect the power cord to your grill. Then plug the power cord into a properly grounded/earthed electrical outlet protected by a Ground Fault Circuit Interrupter (GFCI).

NOTE: Plug appearance may vary by region.



WARNING! ELECTRICAL SHOCK HAZARD
HAZARDOUS VOLTAGE IS PRESENT, WHICH CAN SHOCK, BURN, OR CAUSE DEATH.

- GROUND FAULT CIRCUIT INTERRUPTER (GFCI) PROTECTION MUST BE PROVIDED ON THE CIRCUIT(S) OR OUTLET(S) TO BE USED FOR THE OPERATION OF THIS TRAEGER GRILL.



To add pellets, open the hopper lid and inspect for any foreign objects in the auger. Fill the hopper with pellets at least to the safety grate and close the lid.

USE ONLY TRAEGER HARDWOOD PELLETS. This product is developed and tuned using only Traeger pellets. Traeger pellets are crafted to meet strict quality and performance standards. Using pellets not manufactured by Traeger may result in inconsistent performance, poor flavour, and temperature inconsistency.

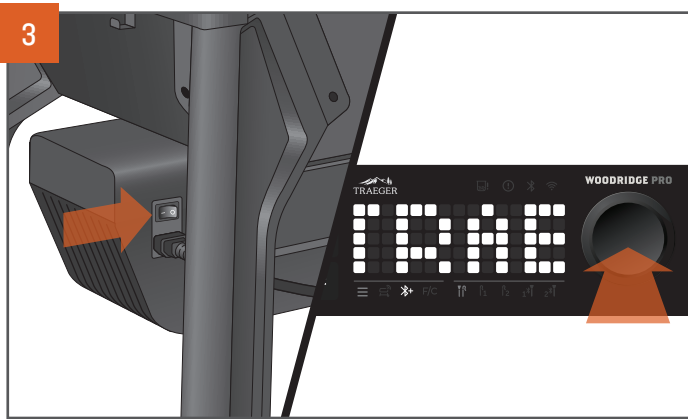

Press the main power switch, located on the back of the auger box, to ON (I). Press the selection dial to wake up the controller. "TRAEGER" will scroll across the screen, indicating the grill is on.

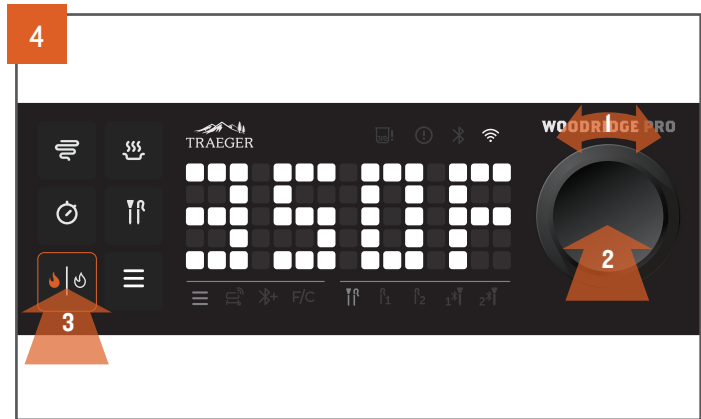

Turn the selection dial to set the grill's temperature to 350°F (177°C), then press the dial. Press the ignite/shutdown button.



PRO TIP: This seasoning process is important to ensure proper grill performance. Make sure that all internal components have been properly installed prior to this seasoning cycle and that there is no food on the grill grates during this cycle.

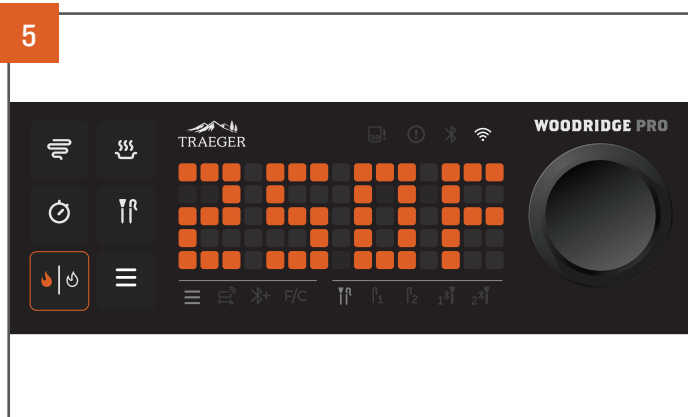

The grill temperature will display as it increases to the set temperature.

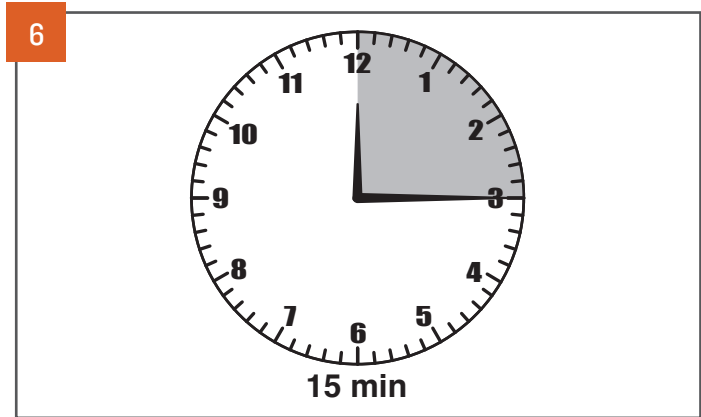

Once the grill has reached 350°F (177°C), let it run for 15 minutes. While the grill is seasoning, you may see dark or excessive smoke and ash; this is normal and will be less on future startups.

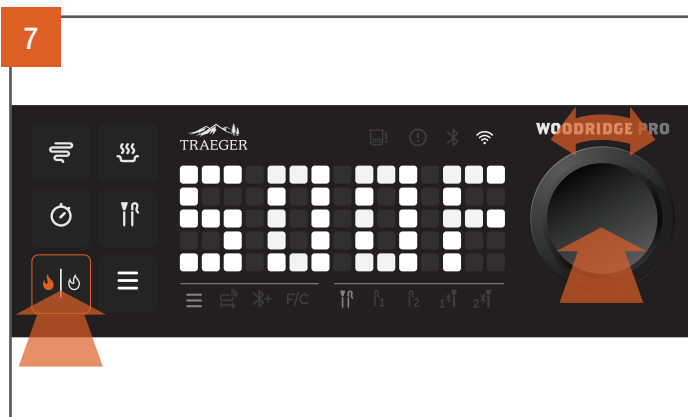

After 15 minutes at 350°F (177°C), increase the temperature to 500°F (260°C).

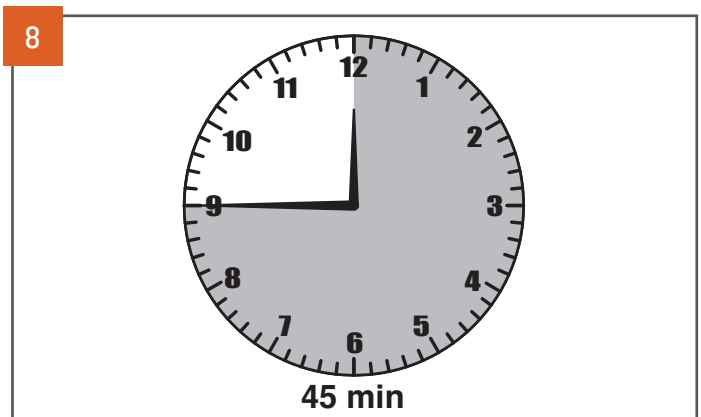

Once the grill has reached 500°F (260°C), let it run for another 45 minutes to ensure seasoning is completed properly.

NOTE: Getting to first-time seasoning temperature may take up to an hour.



ONBOARDING PART 2: SEASONING YOUR GRILL CONTINUED

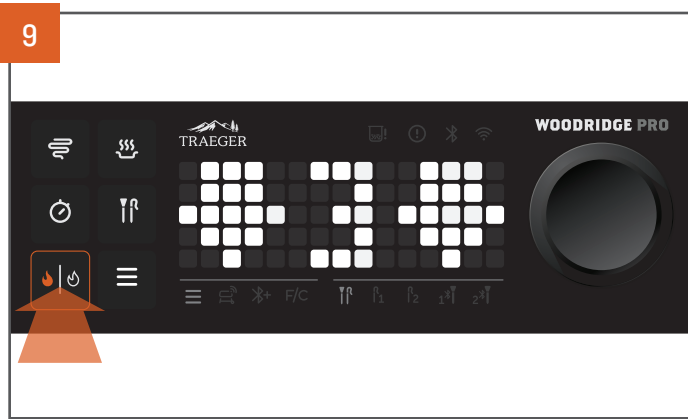

After 45 minutes at 500°F (260°C), shut down the grill and let the shutdown cycle complete. To shut down your grill, press and hold the ignite/shutdown button or the selection dial for three seconds until the display shows the shutdown animation.

NOTE: Always initiate a shutdown cycle after each and every cook.

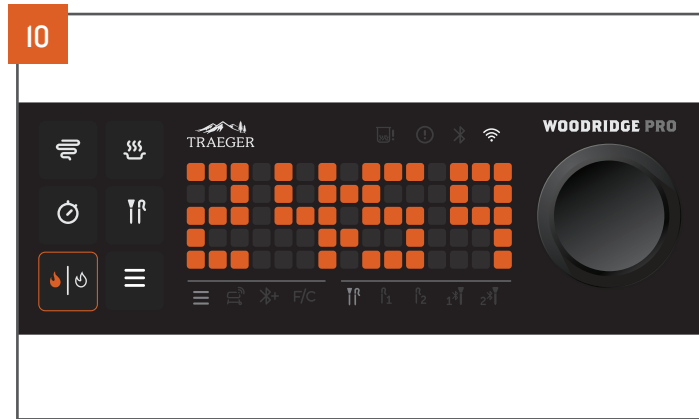

A countdown timer begins while the grill is shutting down. You will hear the fan continue to run.

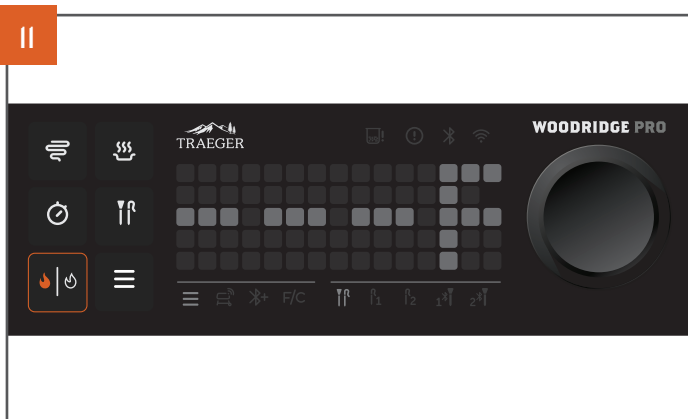

Once this countdown is complete, the shutdown cycle is complete.

NOTE: It is normal to observe ash on the drip tray and/or grill grates after seasoning. Simply wipe away ash on grill grates prior to your first cook.

MAINTAINING YOUR GRILL

Do you love bacon, sausage, and brisket? We do, too, but after cooking these fattier cuts, it's more important than ever to remove grease from the grill. Fortunately, it's easy to do. When the grill has cooled to a warm temperature, scrape grill grates and wipe up this grease from the drip tray (be careful not to burn yourself). This will ensure that everything runs smoothly the next time you fire up, especially if you plan to cook something hot and fast!

1. BEFORE EACH COOK:

Remove any buildup from the drip tray, or replace the drip tray liner. Check the EZ-Clean Grease & Ash Keg, empty if full, and replace with a new EZ-Clean Grease & Ash Keg liner.



PRO TIP: Cover the drip tray only with genuine Traeger branded Drip Tray Liners. Using foil or other materials will significantly impact the performance of the grill and could damage the drip tray or grill.

2. AFTER EACH COOK:

After shutdown, remove any excess food from the grates while still warm. Scrape all grease into the EZ-Clean Grease & Ash Keg. Reinstall the Ember Shield.

NOTE: When scraping out grease, do not use a metal scraper.

WARNING To avoid injury, ensure all ash is cooled before cleaning.

3. MONTHLY:

Check the firepot and remove ash in, around, and underneath. Vacuum the ash from the inside of the firepot. Scrape creosote from the backsplash and the back of the grill lid. Do a final wipe-down of the grill cavity with Traeger Grill Cleaner. Remove and clean out the grease drain chute. Remove ash by sweeping it into the EZ-Clean Grease & Ash Keg.

NOTE: When scraping out creosote, do not use a metal scraper.

4. AS NEEDED:

Replace the EZ-Clean Grease & Ash Keg liner when full.

WARNING Fire Hazard: Grease fires are most frequently caused by failing to properly maintain the grill by not cleaning the grease from the grill on a consistent basis.

WARNING Press the main power switch to OFF (0) and disconnect the power cord before initiating any of the maintenance below.

