

# PAIGALDUS- JUHEND

## WOODRIDGE PRO

Skannige animeeritud samm-sammulisi juhiseid

---

### **OLULINE TEADE / IMPORTANT NOTICE**

See tõlge on antud üksnes teenusena. Tootega kaasasolev ingliskeelne paigaldusjuhend on õiguslikult siduv dokument. Lahknevuste korral on ülimuslik ingliskeelne versioon.

This translation is provided as a courtesy service only. The original English assembly guide included with the product is the legally binding document. In case of any discrepancy, the English version shall prevail.

# ÕIGUSLIK TEADE JA TÕLGE

See dokument on eestikeelne tõlge paigaldusjuhendist, mille pakub Traeger Pellet Grills Europe ApS üksnes teenusena.

Tootega füüsiliselt kaasas olev ingliskeelne originaaljuhend on ainus õiguslikult siduv dokument. Selle tõlke ja originaaldokumendi vahelise lahknevuse, mitmetähenduslikkuse või vastuolu korral kehtib alati ingliskeelne versioon.

**OLULINE:** Originaalse ingliskeelse juhendi samm-sammulised paigaldusskeemid, riistvara illustratsioonid ja paigalduspildid on grilli õigeks kokkupanemiseks vajalikud. See tõlge sisaldab ainult tõlgitud teksti; visuaalsete paigaldusetappide jaoks viidake originaalsele ingliskeelsele juhendile või skannige füüsilise juhendi QR-kood animeeritud juhiste nägemiseks.

Tehnilise abi, garantii või klienditeeninduse osas vaadake kontaktteavet selle dokumendi lõpus või külastage [support.traeger.com](https://support.traeger.com).

## ENGLISH NOTICE

This document is an Estonian translation of the assembly guide provided by Traeger Pellet Grills Europe ApS solely as a courtesy service. The original English assembly guide is the only legally binding document.

# ENNE ALUSTAMIST

LUGEGE SEE PAIGALDUSJUHEND JA OMA KASUTUSJUHEND LÄBI ENNE TRAEGER-GRILLI PAIGALDAMIST JA KASUTAMIST. Juhiste eiramine võib põhjustada varalist kahju, kehavigastusi või isegi surma.

## PAIGALDUSPIIRKOND

Grilli kasutamisel hoidke MINIMAALSELT 50,8 cm (20 tolli) vahemaa grillist mistahes lähedalasuvate süttivate materjalideni, sealhulgas puidust käsipuud, hoonete vooderdused, aknaraamid, mööbel, puud ja prügikastid jne.

Ärge paigaldage ega kasutage seda grilli süttivatel põrandatel või pindadel, siseruumides või põleva lae või väljaulatava katuse all.

Lugege kasutusjuhendit täiendavate juhiste ja hoiatuste saamiseks.

3,7 × 3,7 m (12 jalga × 12 jalga) PAIGALDUSALA

PRO-NÕUANNE: Soovitame grilli kokku panna kahe inimese poolt.

PRO-NÕUANNE: Ehitage saatekarbi põhjale kriimustuste vältimiseks.

### HOIATUS — Tuleoht

Vajalike vahemaade (õhuruumide) mittehoidmine süttivate materjalide ja grilli vahel on oluline tulekahjude põhjus. On väga oluline, et toode paigaldataks ainult vastavalt nende juhiste ja kasutusjuhendile.

### HOIATUS — Elektrilöögi oht

Esinevad ohtlikud pinged. Sellele Traeger-grillile kasutatavatele ahelatele või pistikupesadele tuleb paigaldada rikkevoolukaitse (GFCI). Tõmmake pistik enne elektrikomponentidega seotud paigaldustööd välja.

## LAHTI PAKKIMINE JA RÜHMITAMINE

Kui kõik komponendid on lahti pakitud, paigutage osad saatekarbi põhjale. Rühmitage karbid nende tunnussümbolite järgi:

- SEKTSIOONID JA JALAD — Compartments & Legs
- RATTAD JA JALAKATTED — Wheels & Hooves
- JUHTSEADMED JA RIIULID — Controls & Shelving
- KAAS JA GRILLI SISEMISED OSAD — Lid & Grill Internals

## RIISTVARA — ÜLEVAADE

Riistvarapakett sisaldab kruvisid, polte, mutreid, splinte, paigaldusplaate ja silikoonpuhvleid. Iga riistvaraelement on tähistatud tähega (A, B, C, ...) ja kujutatud 1:1 skaalas originaalses ingliskeelses juhendis, et saaksite riistvara füüsiliselt skeemiga võrrelda. Kasutage riistvaraelementide tuvastamiseks originaalset ingliskeelset juhendit.

Poldid ja kruvid	Bolts and screws — tavaliselt tähistatud A, B, C mõõtmetega nagu 1/4-20 × 3/4 tolli, 5/16-18 ×, jne.
Mutrid ja seibid	Nuts and washers — lamedad seibid, vedruseibid.
Splindid ja lukustusmehhanismid	Cotter pins, round cotter pin, clevis pin — rataste teljedele ja liigenditele.
Paigaldusplaadid	Mounting plates — kontrolleriile ja teokarbile.
Silikoonpuhvrid	Silicone bumpers — kaanel ja teistel kokkupuutepindadel.

# PAIGALDUSMENETLUS — ÜLEVAADE

Järgige originaalse ingliskeelse juhendi samm-sammulisi skeeme. Allpool lühike ülevaade järjekorrast:

Samm 1 — Pange kokku raam ja jalad: Kinnitage jalad alumise sektsiooni külge, paigaldage ristlatid ja pingutage poldid.

Samm 2 — Paigaldage rattad ja jalakatted: Pange rattad ühele poole ja jalakatted teisele. Kasutage splinte.

Samm 3 — Paigaldage teokarp: Grilli korpuse tagaküljele. Pingutage kõik kruvid korralikult.

Samm 4 — Paigaldage kontrollid ja ühendused: Ühendage kõik juhtmed (temperatuuriandur, kontrolleri pistik, ventilaator).

Samm 5 — Sisekomponendid: Pange sädemekaitse, rasvaaravoolurenn, soojusplaat ja tilkumisalus paika.

Samm 6 — Grillrestid: Pange alumine ja ülemine grillrest paika.

Samm 7 — Riiulid ja tarvikud: Paigaldage võimalikud P.A.L. POP-AND-LOCK-rööpad ja külglaud.

Samm 8 — Lõppkontroll: Kontrollige, et kõik kruvid on pingutatud, kaas avaneb/sulgub korralikult ja rasvaaravool on õigesti paigutatud.

## PÄRAST PAIGALDAMIST

Kui grill on kokku pandud, järgige kasutusjuhendi samme Wi-Fi ühendamiseks ja grilli sisseelamiseks (seasoning) enne toidu valmistamist.

- Vaadake kasutusjuhendit täielikeks kasutus- ja ohutusjuhisteks.
- Kasutage ainult Traegeri puidugraanuleid.
- Ühendage grill Traegeri rakendusega WiFIRE kaudu ja laadige alla värskemad püsivara värskendused.
- Tehke kohustuslik sisseelamistsükkel enne esimest toiduvalmistamist.

## VIIDE INGLISKEELSELE ORIGINAALILE

Originaalne ingliskeelne juhend sisaldab visuaalseid elemente, mis on vajalikud grilli õigeks kokkupanemiseks: 1:1 skaalas riistvaraskeemid, samm-sammulised joonised, saatekarpide tunnussümbolid ja animeeritud videojuhised QR-koodi kaudu. Me ei saa neid visuaalseid elemente selles tõlkes taasesitada.

Skannige füüsilise juhendi QR-kood või külastage [traeger.com/support](https://traeger.com/support), et näha animeeritud paigaldusetappe.

## TEENINDUS

TRAEGERI LEGENDAARNE KLIENDITEENINDUS on parim, mis on olemas. Kui teil on paigalduse kohta küsimusi, võtke meiega ühendust:

Telefon (rahvusvaheline): [traeger.com/support/international-contact-info](https://traeger.com/support/international-contact-info)

Veebisait: [support.traeger.com](https://support.traeger.com)

Adress: Traeger Pellet Grills Europe ApS — Kattegatvej 40, 2150  
Kopenhaagen, Taani

EU-st väljas asuvatel klientidel tuleb paigaldusabi saamiseks pöörduda oma riigi kohaliku turustaja poole.



# ASSEMBLY GUIDE

## WOODRIDGE PRO WOOD PELLET GRILL



**SCAN FOR  
STEP-BY-STEP  
ANIMATED  
INSTRUCTIONS**



**A MAJOR CAUSE OF FIRES IS FAILURE TO MAINTAIN  
REQUIRED CLEARANCES (AIR SPACES) TO COMBUSTIBLE  
MATERIALS. IT IS OF UTMOST IMPORTANCE THAT THIS  
PRODUCT BE INSTALLED ONLY IN ACCORDANCE WITH  
THESE INSTRUCTIONS.**

**IMPORTANT: RETAIN FOR FUTURE REFERENCE. READ CAREFULLY.**

T18984

©2025 TRAEGER PELLET GRILLS LLC.  
ALL RIGHTS RESERVED.

**TRAERGER PELLET GRILLS LLC**

533 South 400 West  
Salt Lake City, UT 84101

**TRAERGER.COM**

# BEFORE YOU BUILD

PLEASE READ THIS ASSEMBLY GUIDE AND YOUR OWNER'S MANUAL BEFORE INSTALLATION AND USE OF YOUR TRAEGER GRILL. FAILURE TO FOLLOW THE INSTRUCTIONS IN THIS ASSEMBLY GUIDE AND YOUR OWNER'S MANUAL COULD RESULT IN PROPERTY DAMAGE, BODILY INJURY, OR EVEN DEATH.

When using your grill, maintain a MINIMUM distance of 50.8 cm (20 inches) from the grill to any nearby combustibles, including wooden railings, home siding, window frames, furniture, trees, and trash receptacles, etc. Do not install or operate this grill on combustible floors or surfaces, indoors or under a combustible ceiling or overhang. Read the Owner's Manual for additional instructions and warnings.

## SETUP SPACE



**PRO TIP:** Build on the bottom tray of the shipping box to help prevent scratches.

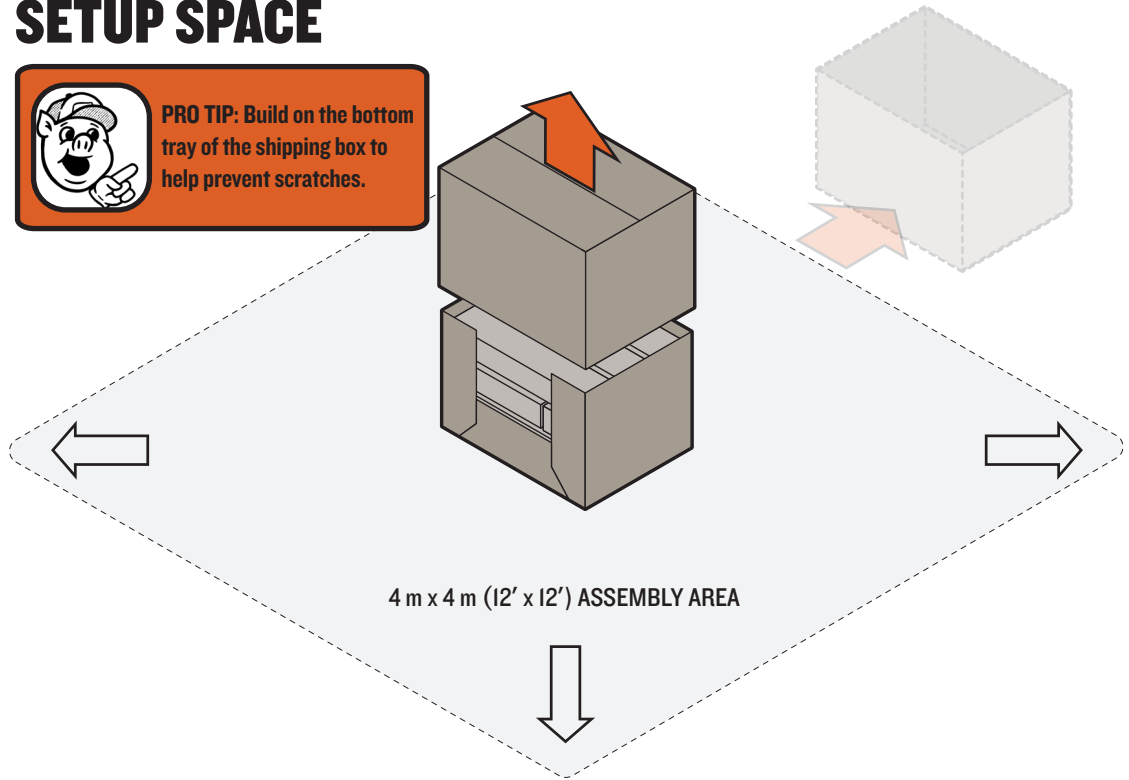

**PRO TIP:** We recommend assembling your grill with two people.

## SETUP

Once all components are unpacked, arrange pieces onto the bottom tray of the shipping box.

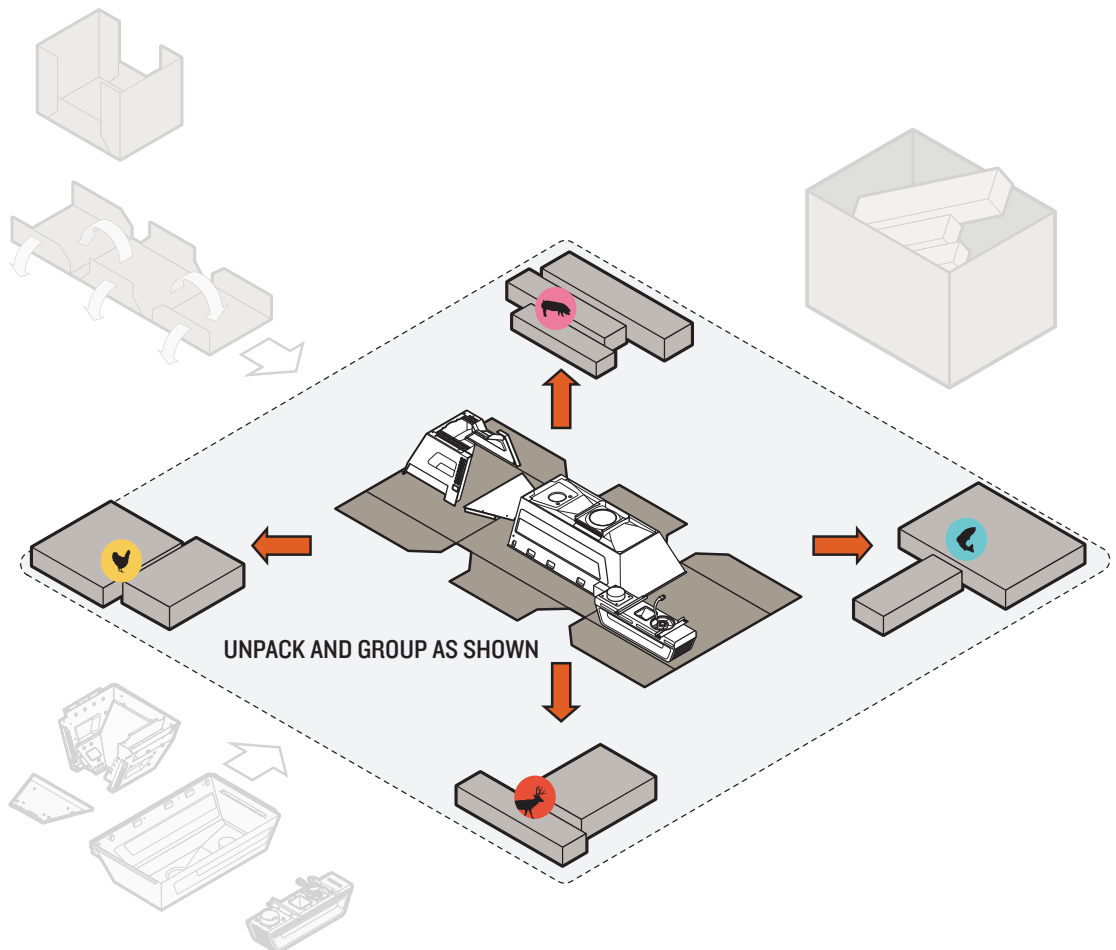

### GROUP BOXES BY THEIR IDENTIFYING SYMBOLS, SHOWN BELOW:





# HARDWARE (TOTAL QUANTITIES)

1:1 SCALE

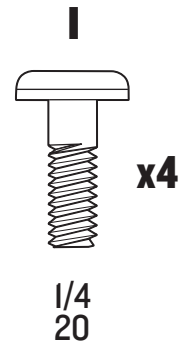
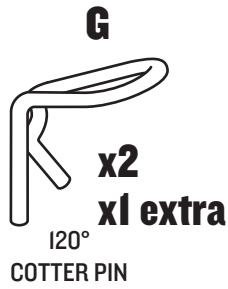
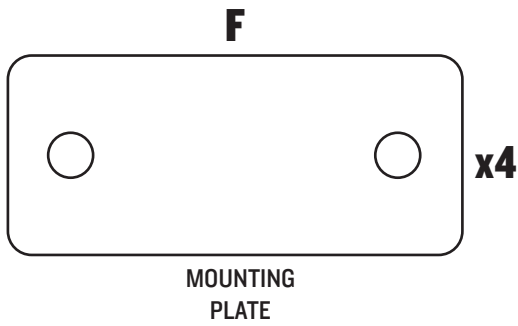
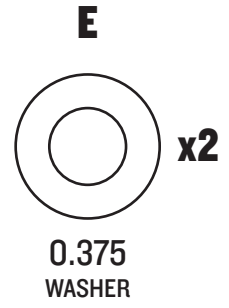
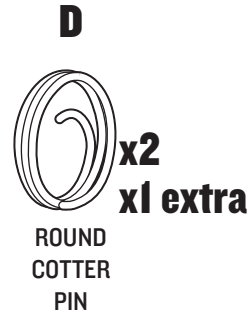
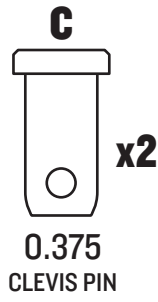
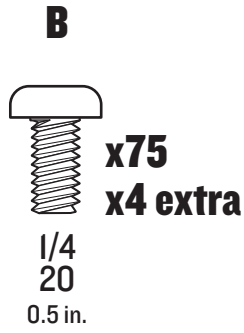
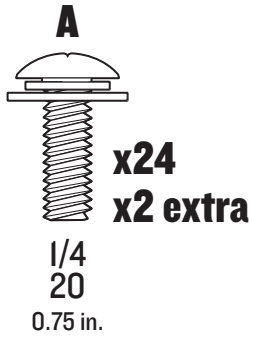



# CHAPTERS

## CHAPTER 1 – PAGE 5 COMPARTMENTS & LEGS

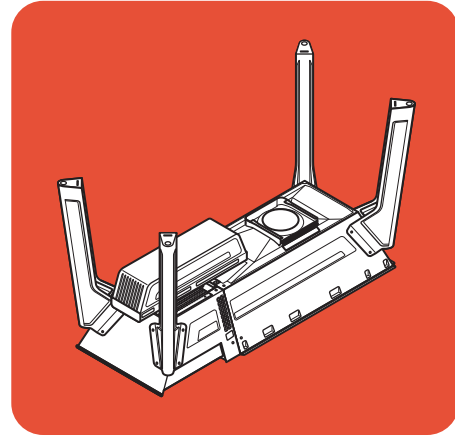

## CHAPTER 2 – PAGE 13 BOTTOM SHELF, WHEELS, & CASTERS

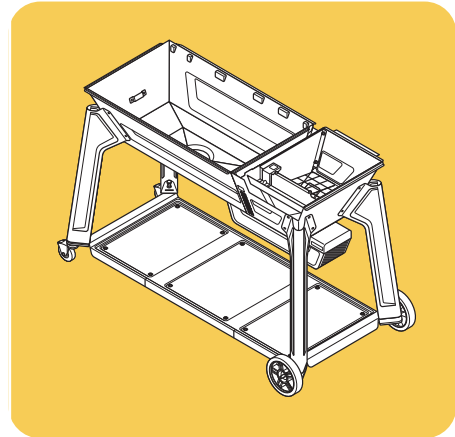
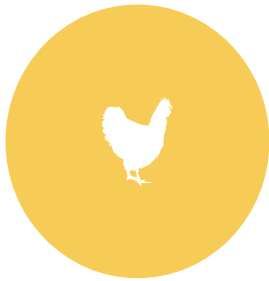

## CHAPTER 3 – PAGE 20 CONTROLS & SHELVING

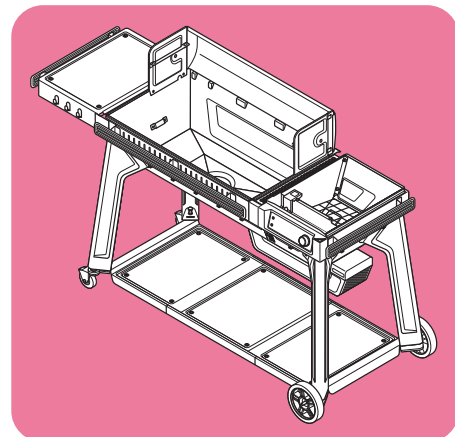
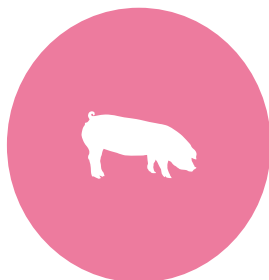

## CHAPTER 4 – PAGE 34 LID & GRILL INTERNALS

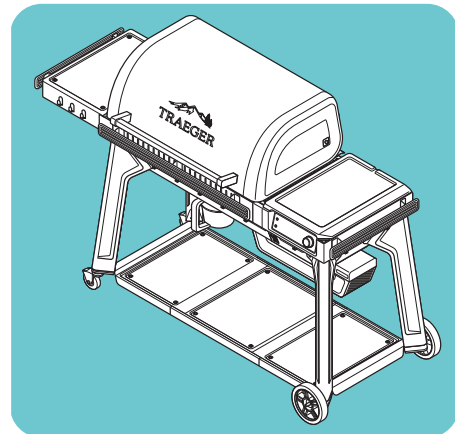

# CHAPTER 1

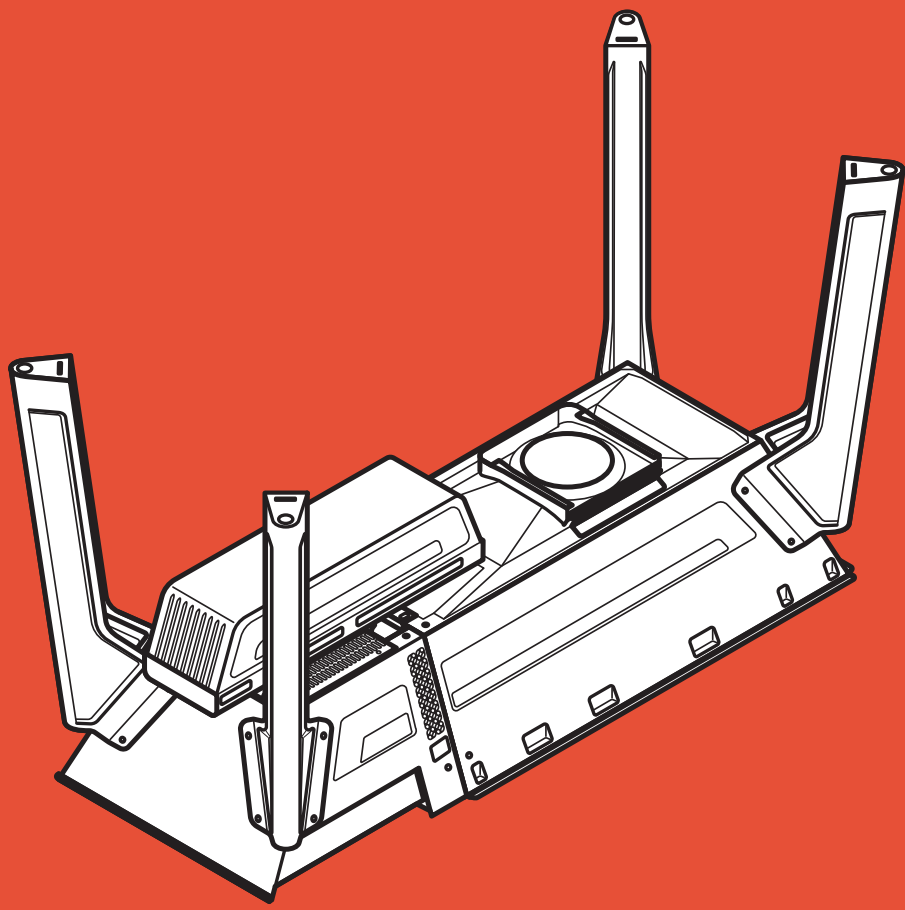

## COMPARTMENTS & LEGS

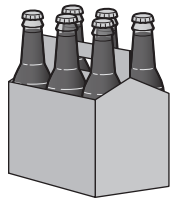
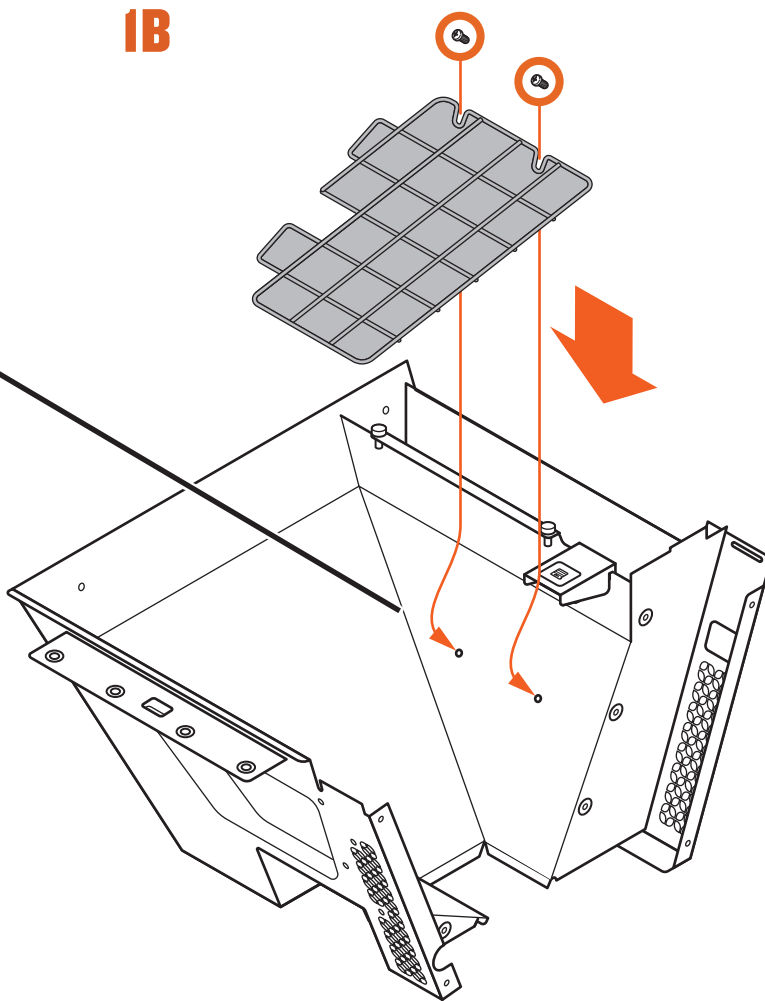
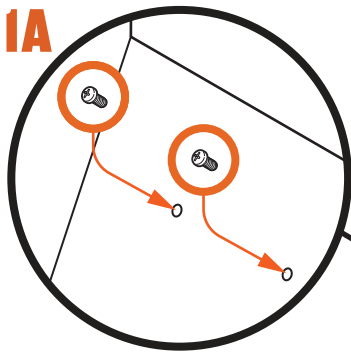
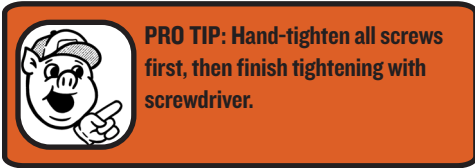
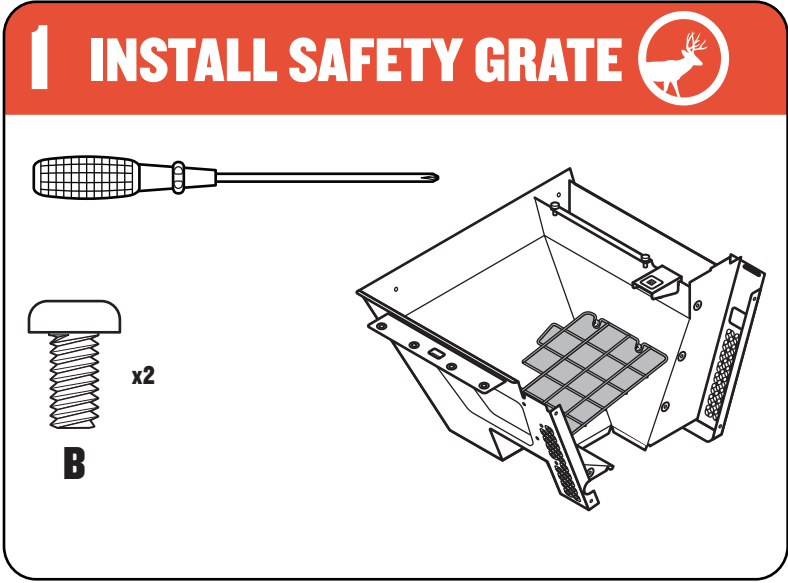
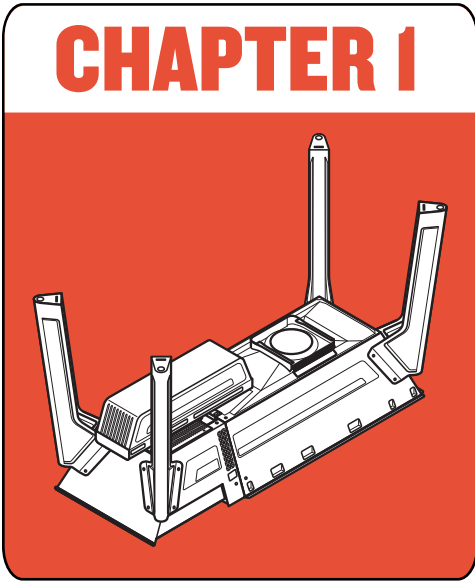



## 2 ASSEMBLE HOPPER

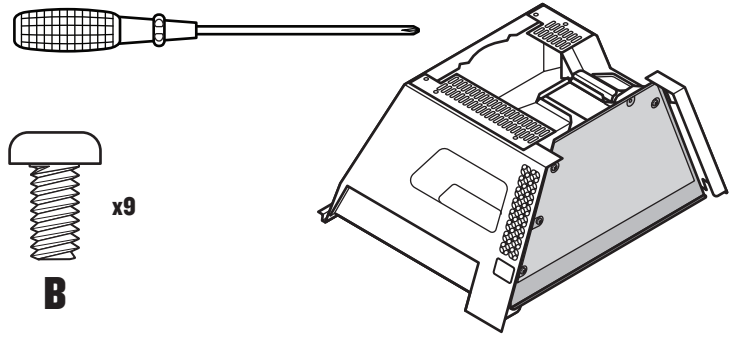

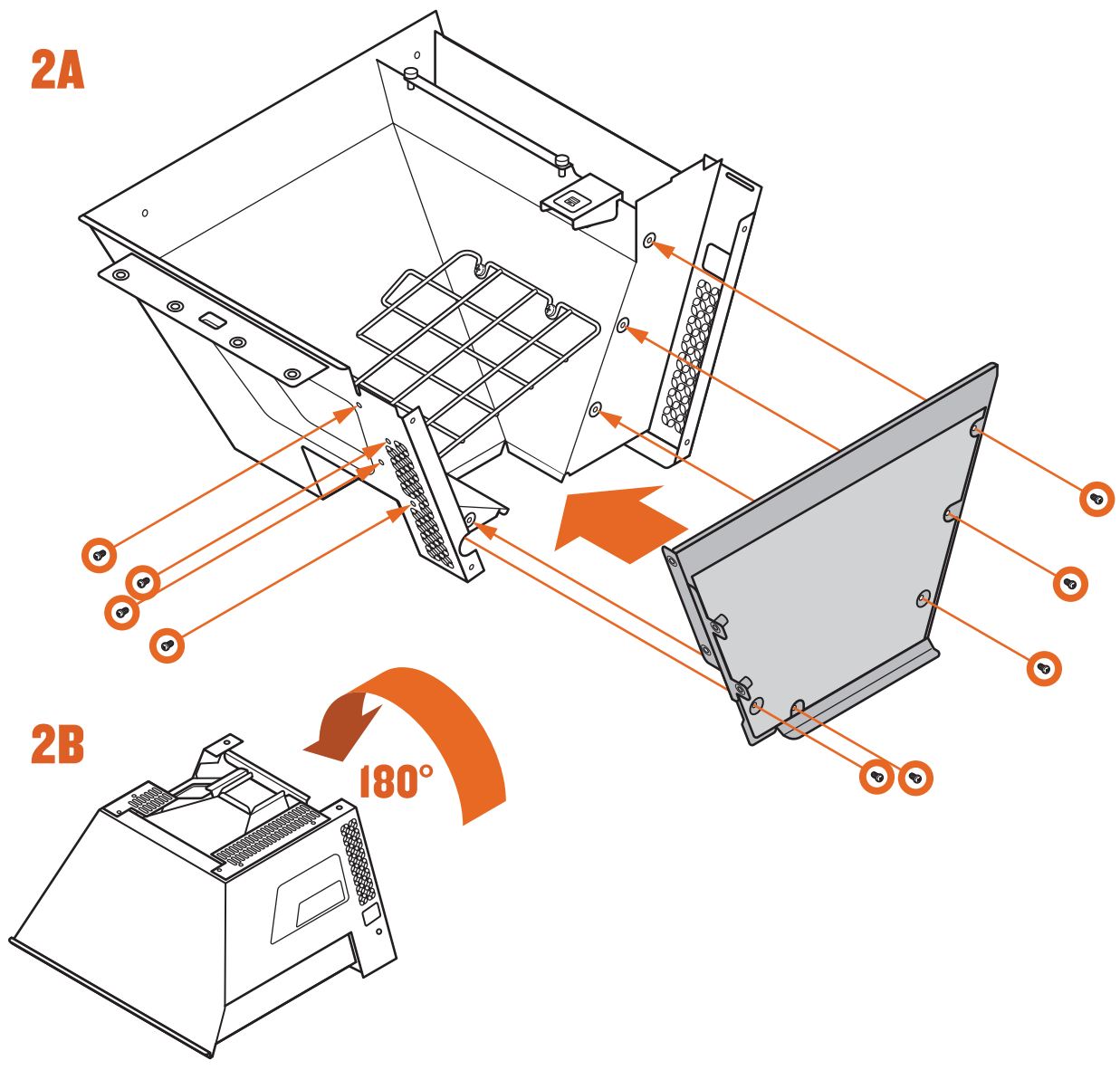

**B** x9



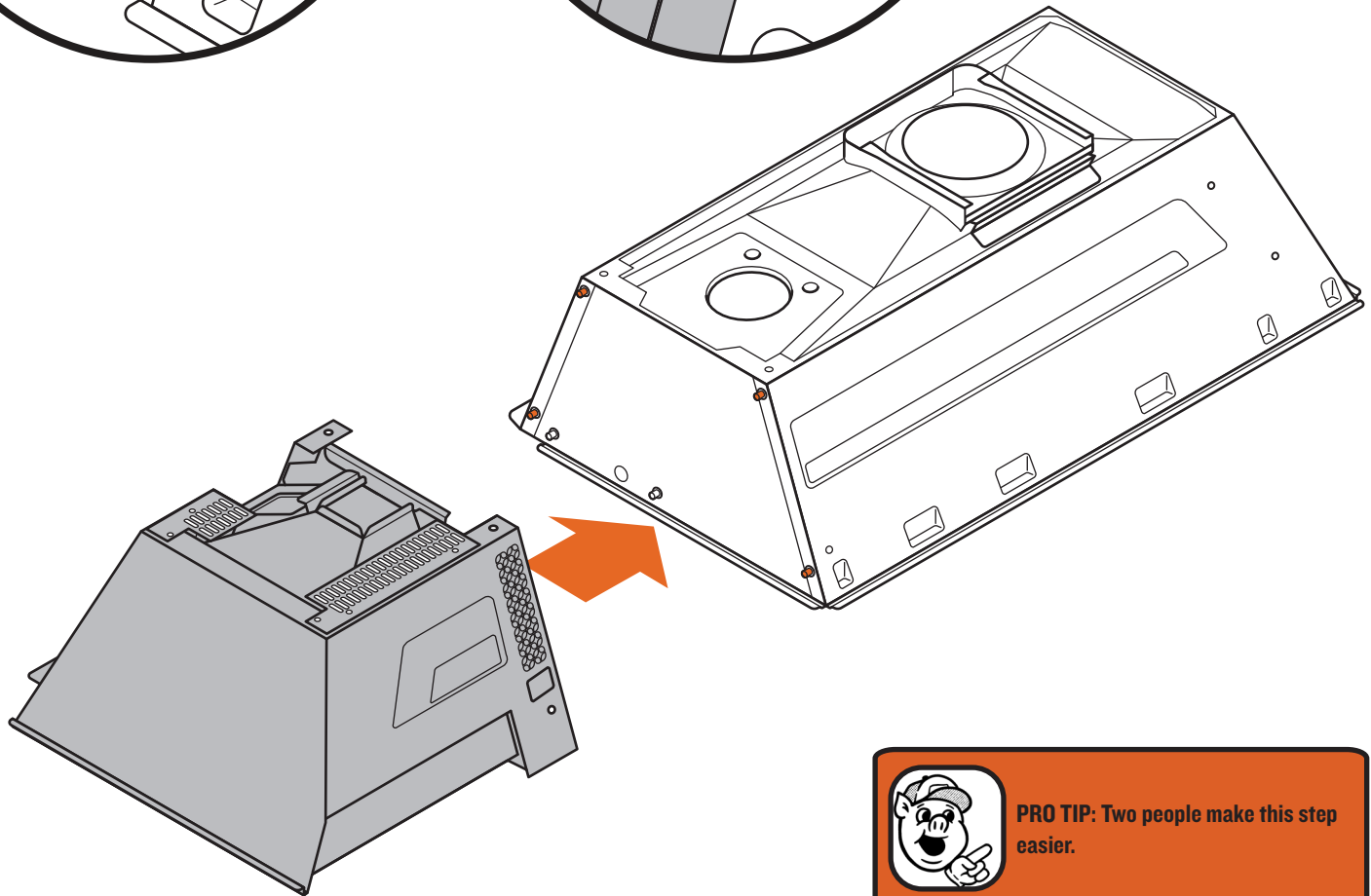
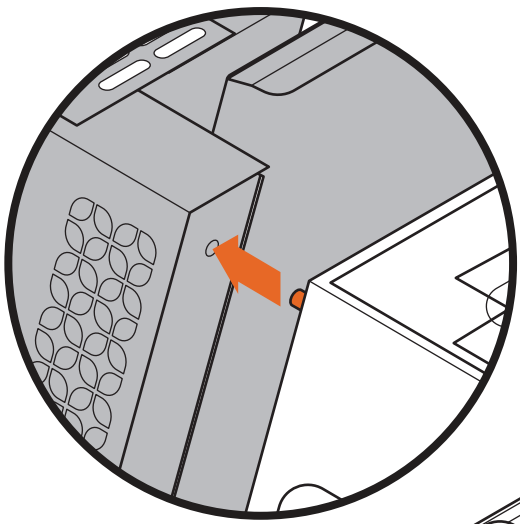
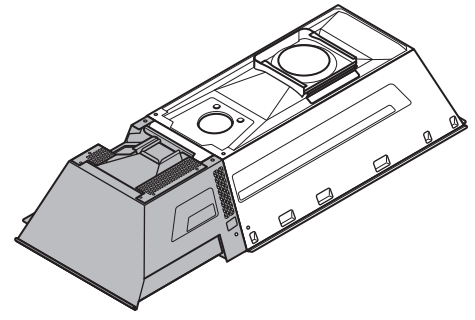

# 3A ATTACH HOPPER TO BODY



 **PRO TIP:** Two people make this step easier.





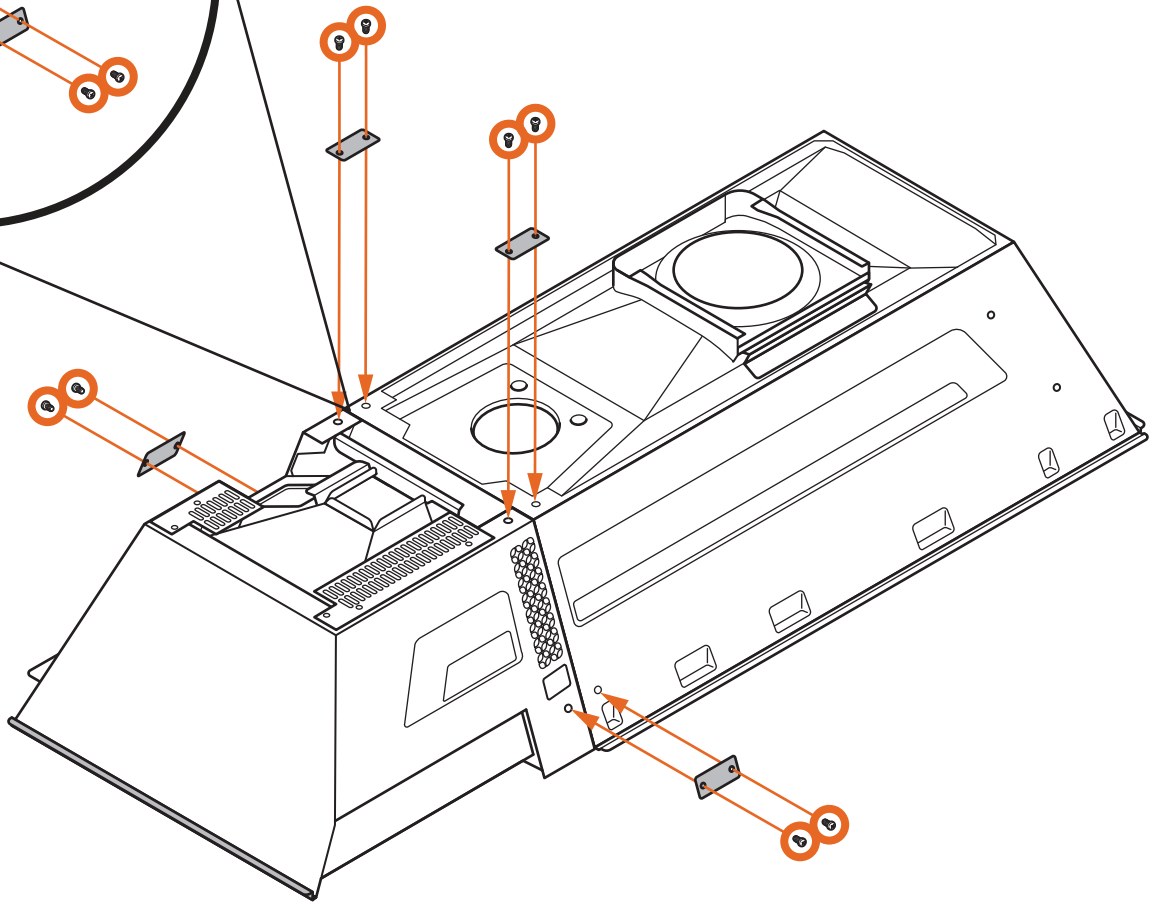
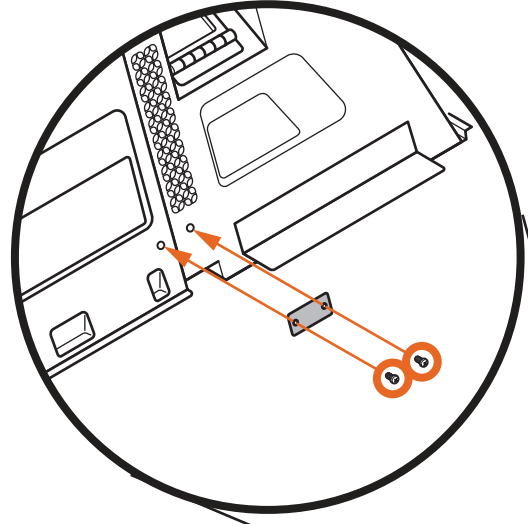
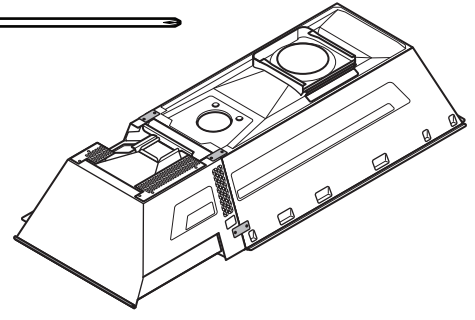
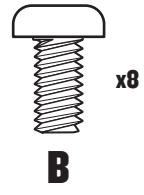
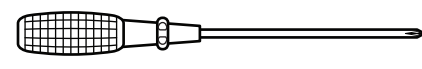

# 3B ATTACH HOPPER TO BODY



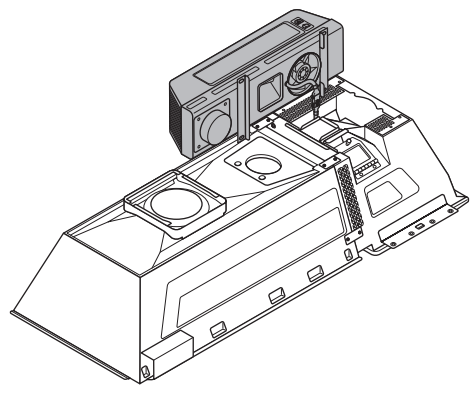
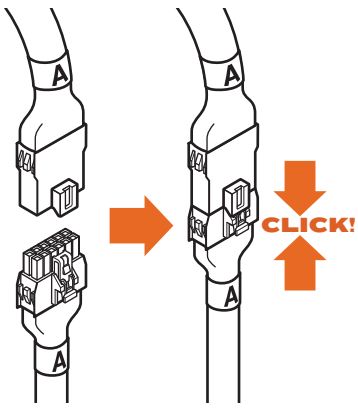

# 4 CONNECT AUGER BOX



 **PRO TIP:** Have a second person hold the auger box while you connect the cord.

 **PRO TIP:** Don't forget to remove the twist tie and tape holding down the cord.

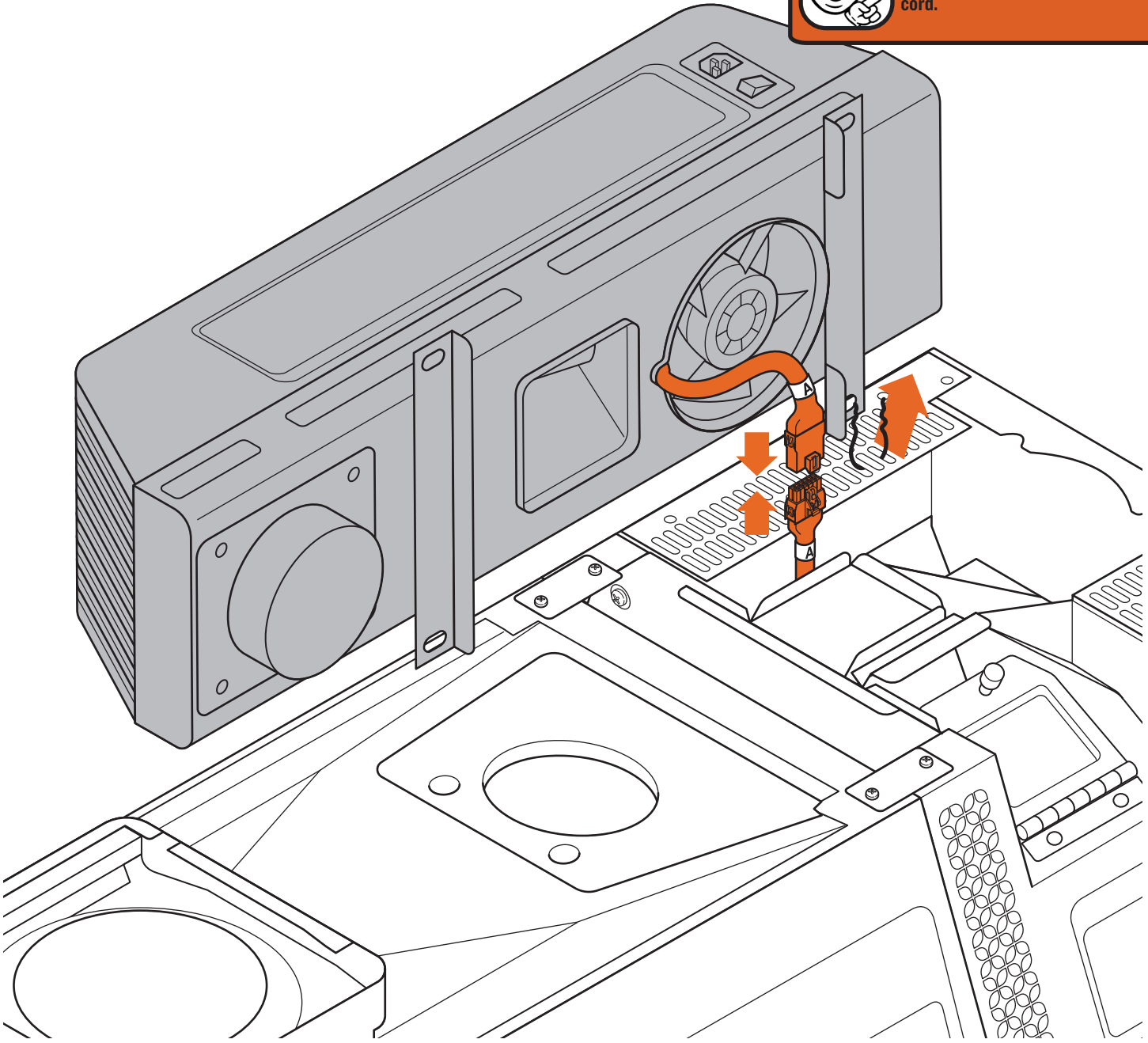



# 5 ATTACH AUGER BOX

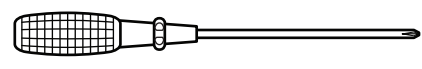

Use **THIS** screw now!

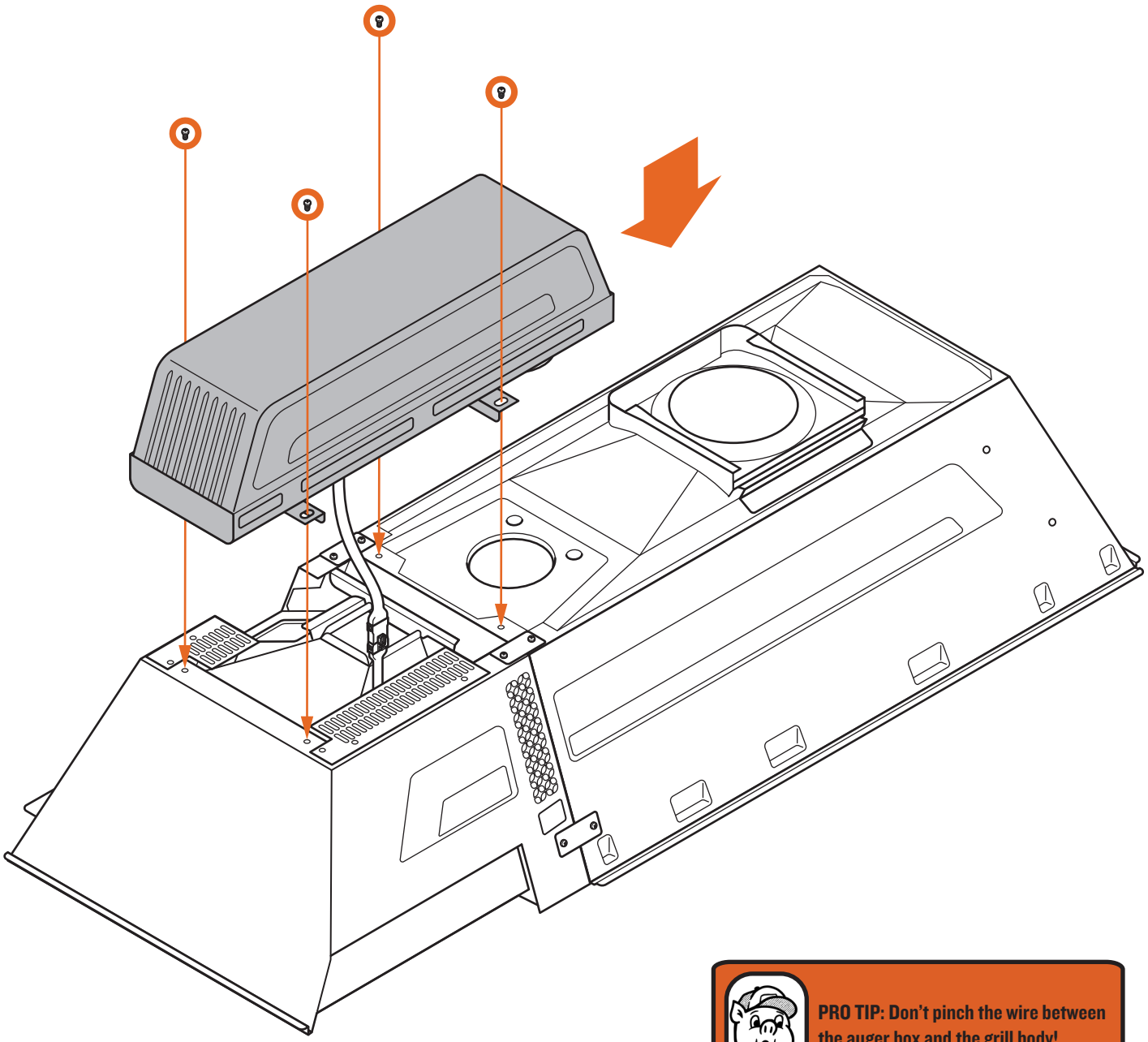
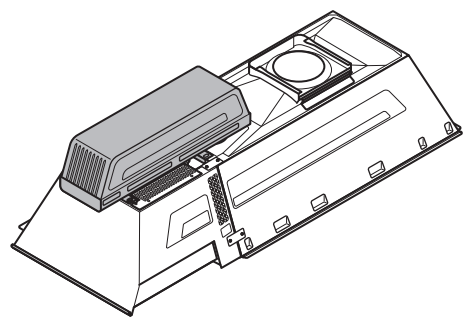
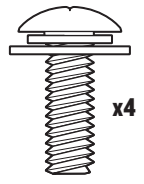

**PRO TIP:** Don't pinch the wire between the auger box and the grill body!



# 6 ATTACH LEGS

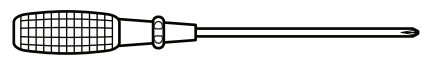

Use **THIS** screw again!

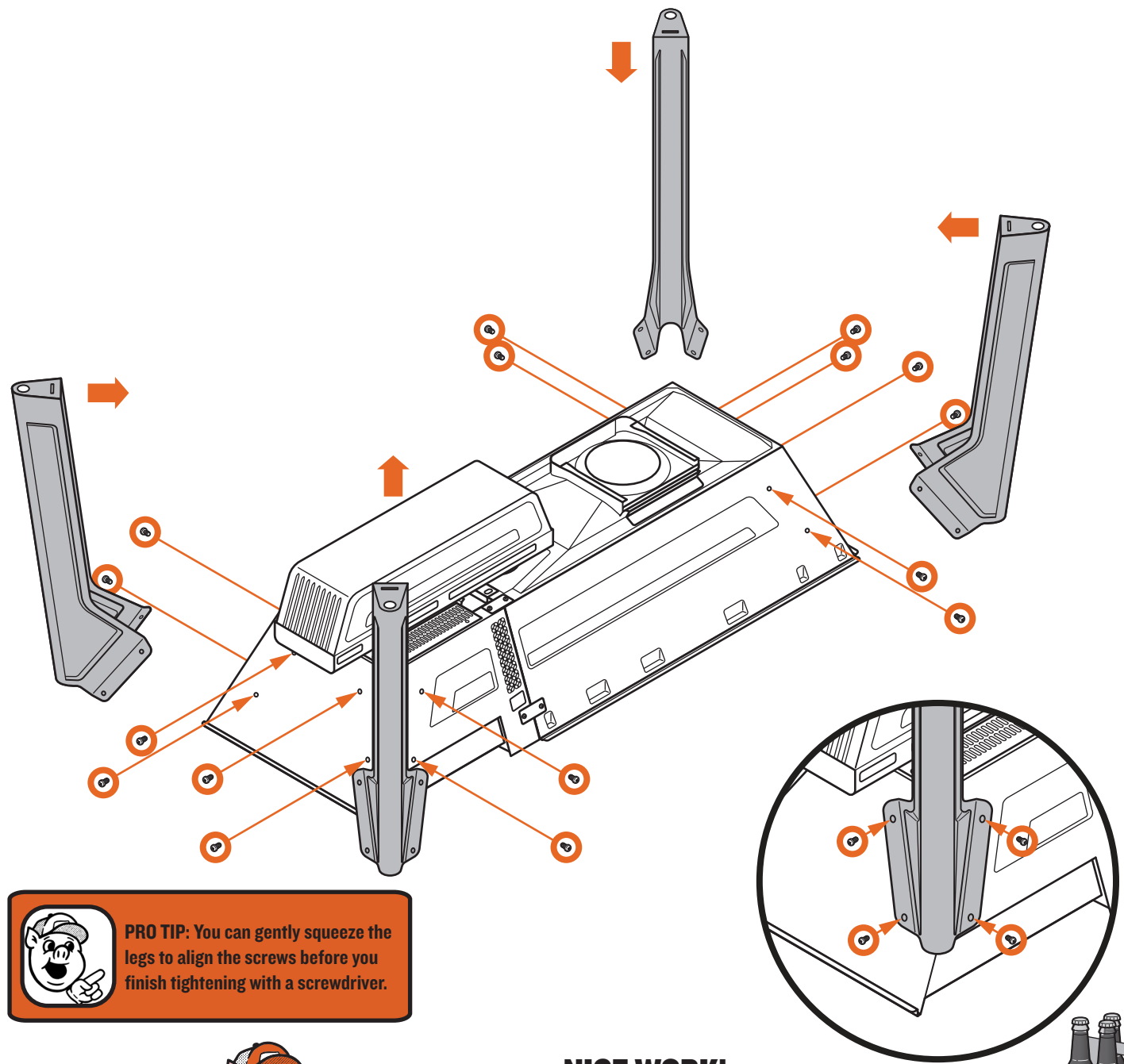
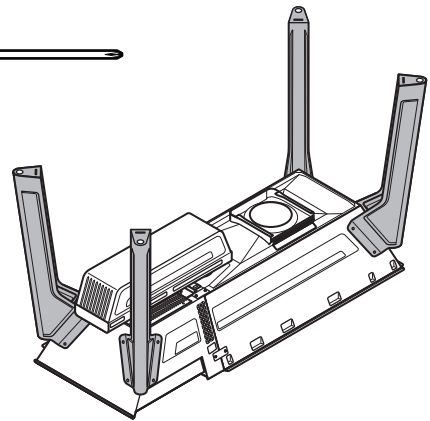
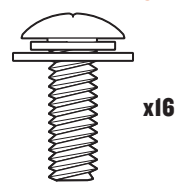

 **PRO TIP:** You can gently squeeze the legs to align the screws before you finish tightening with a screwdriver.



## NICE WORK! CHAPTER I COMPLETE!

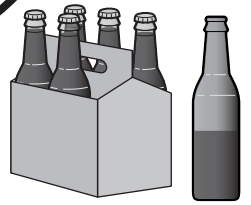

# CHAPTER 2

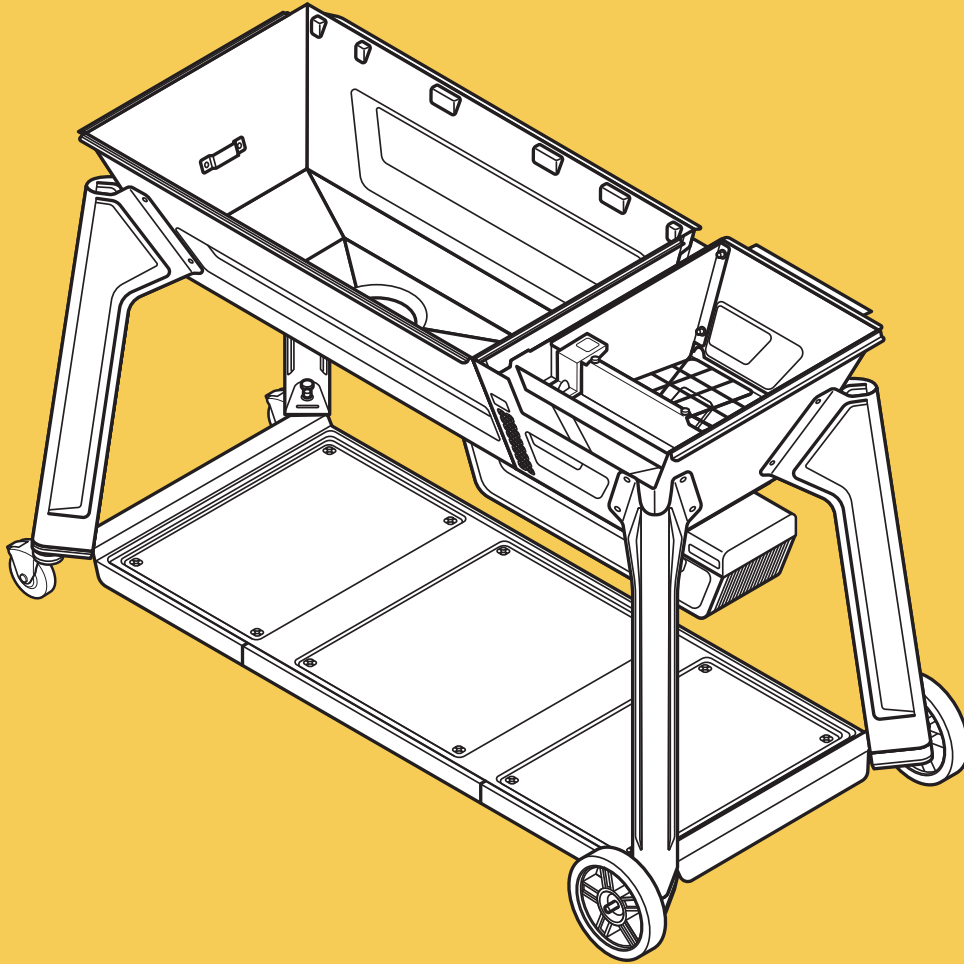

## BOTTOM SHELF, WHEELS, & CASTERS

# CHAPTER 2

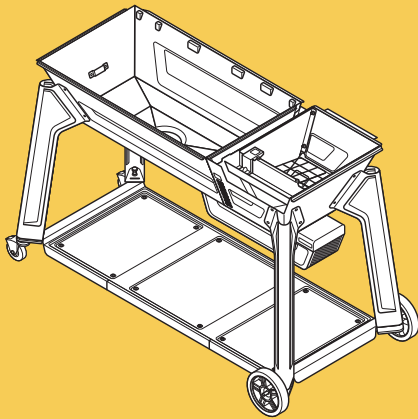

## 1A ASSEMBLE BOTTOM SHELF

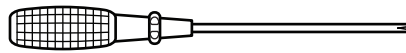

Use THIS screw now!

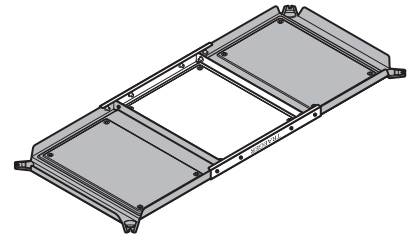
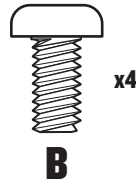

**PRO TIP:** Hand-tighten all screws first, then finish tightening with screwdriver.

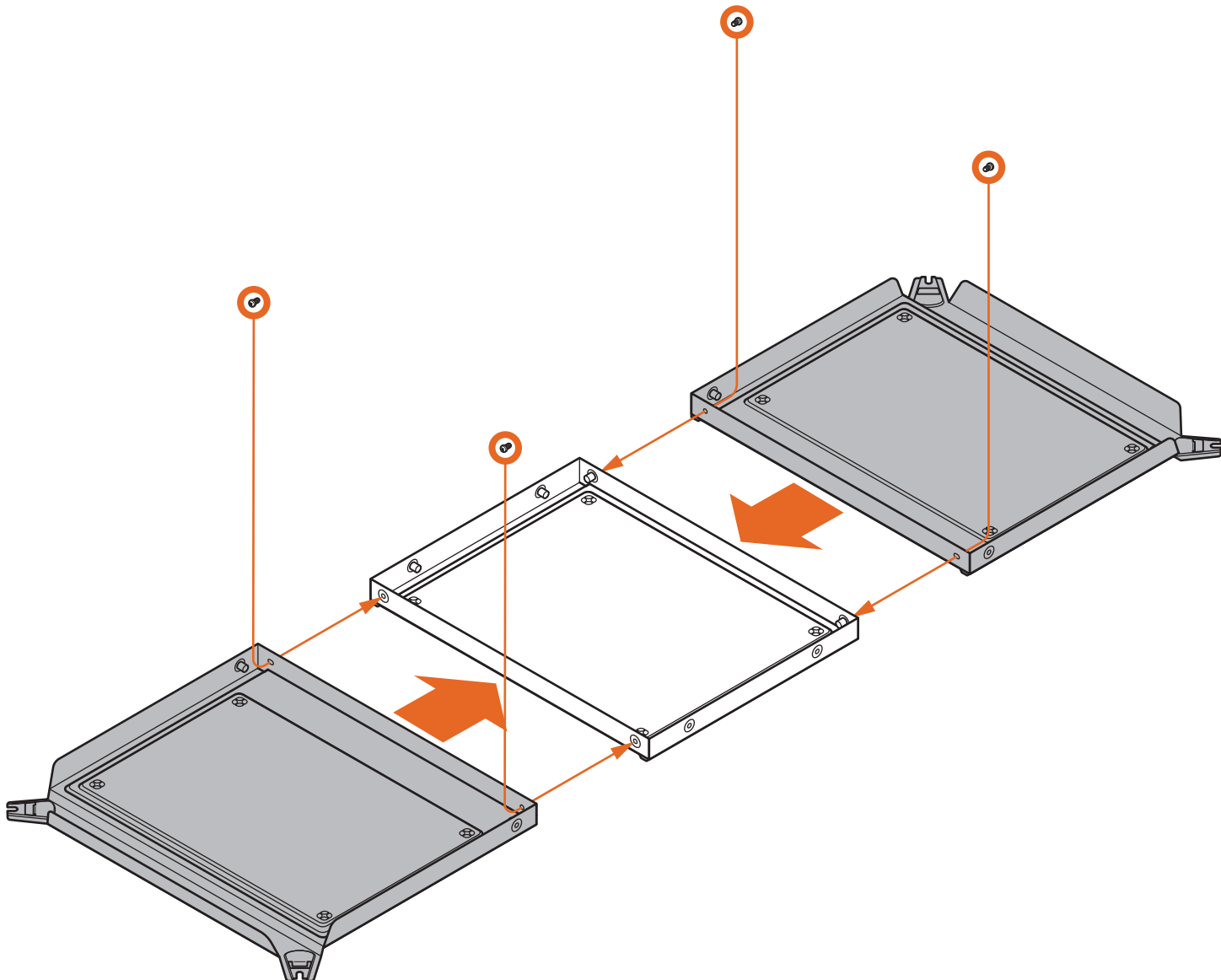



# 1B ASSEMBLE BOTTOM SHELF

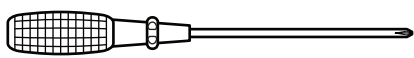
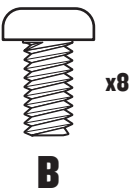
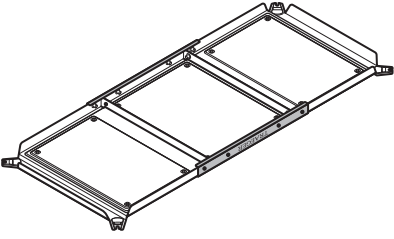
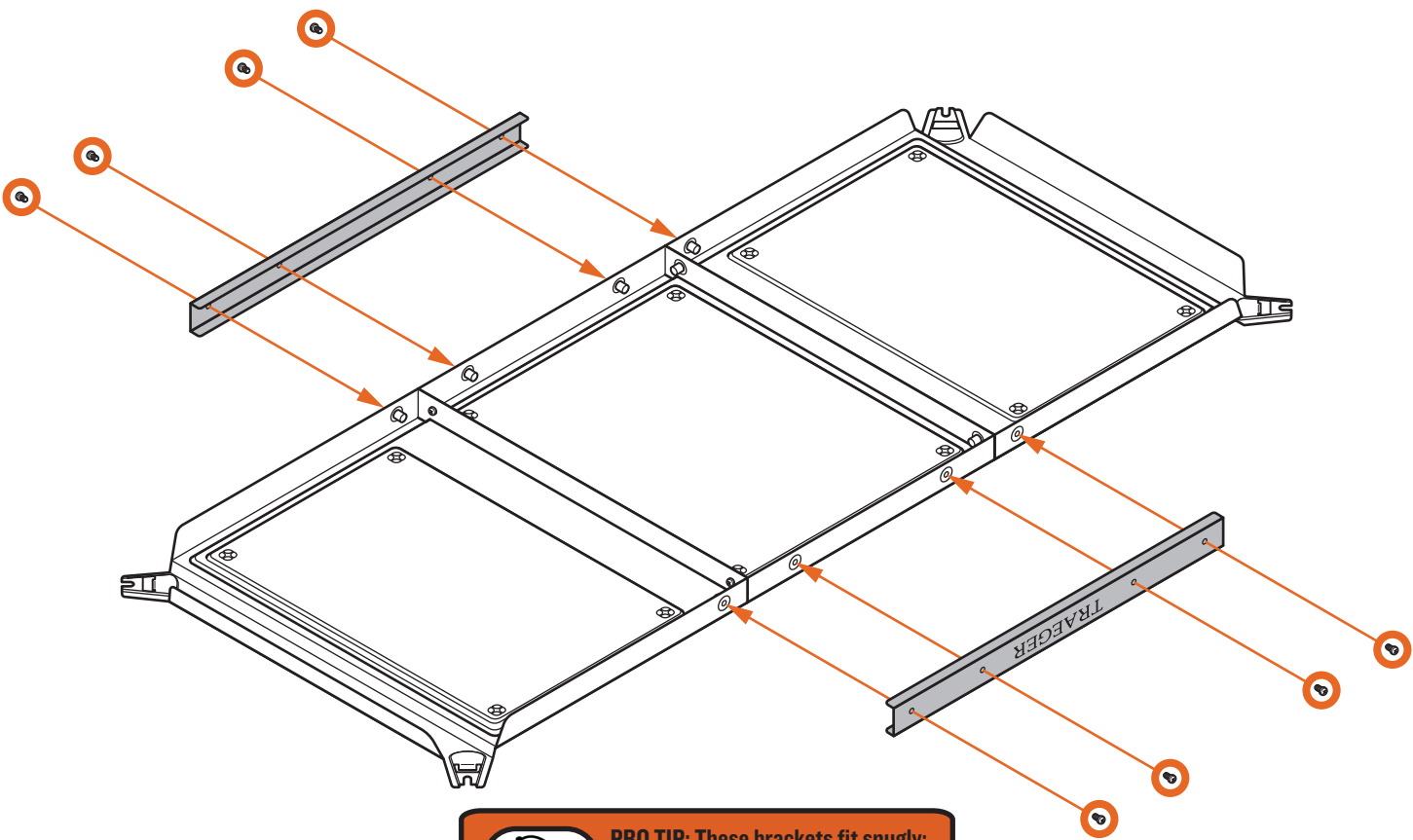

**PRO TIP:** These brackets fit snugly; loosely install all hardware on one bracket before tightening down and moving to the other bracket.

**PRO TIP:** Make sure "Traeger" is upside down.



## 2 ATTACH BOTTOM SHELF

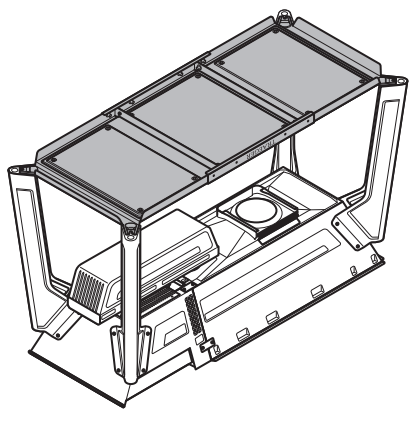

 **PRO TIP:** No screws are needed for this step!

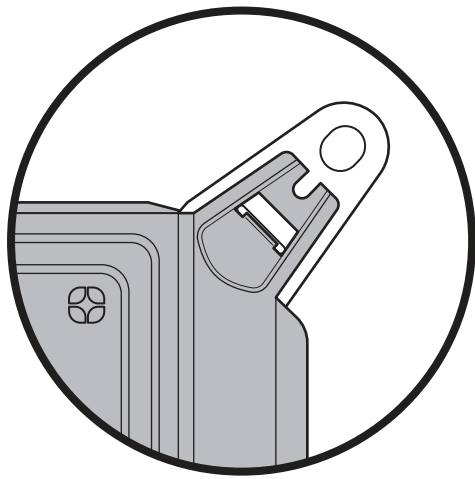
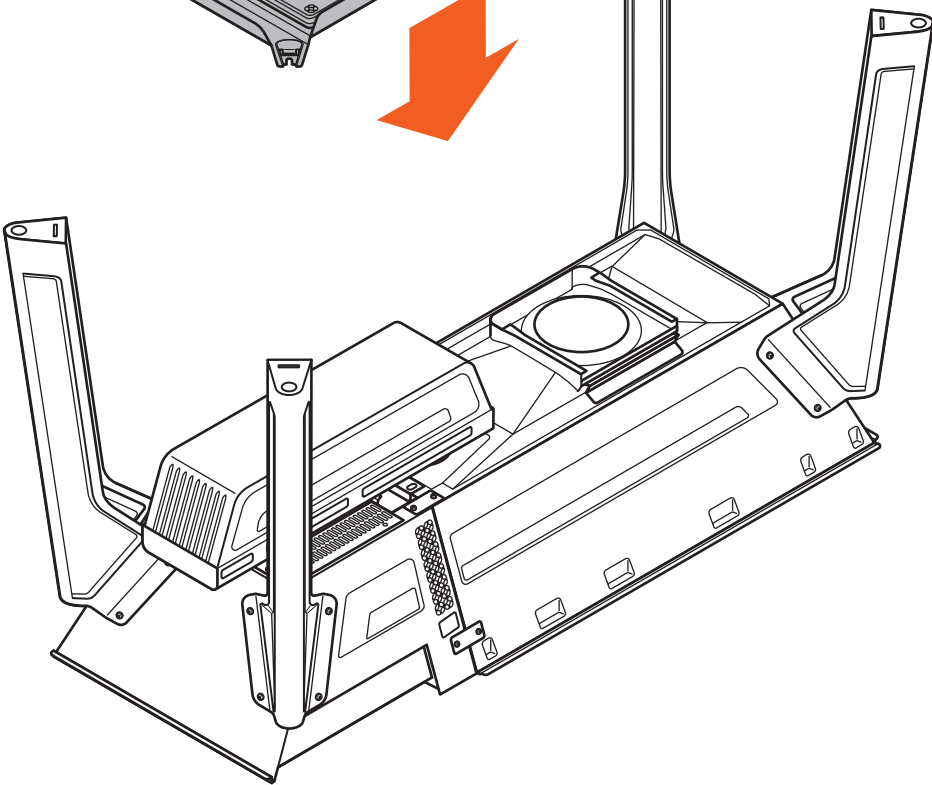
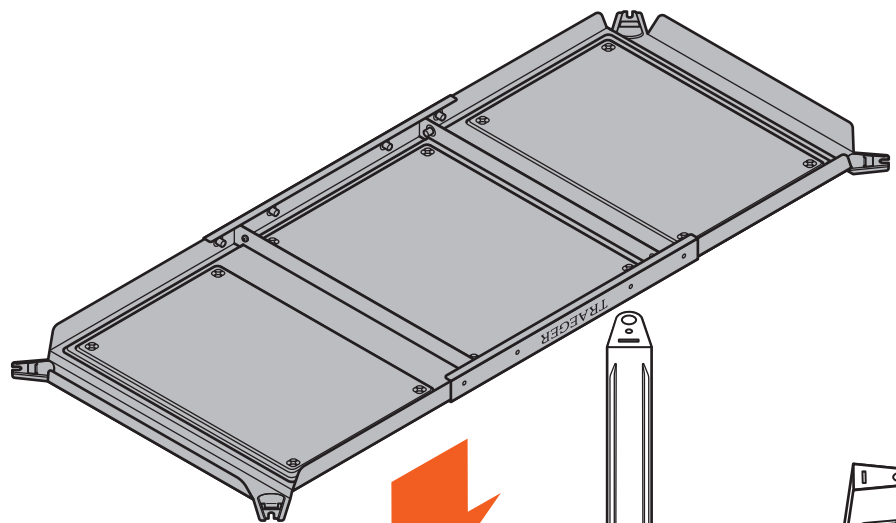

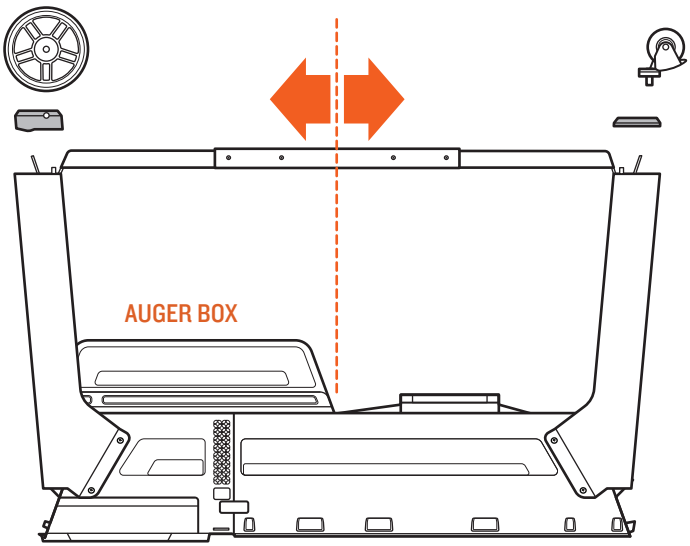

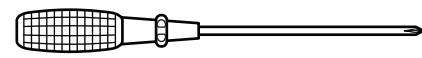

### 3 ATTACH WHEEL HOOVES

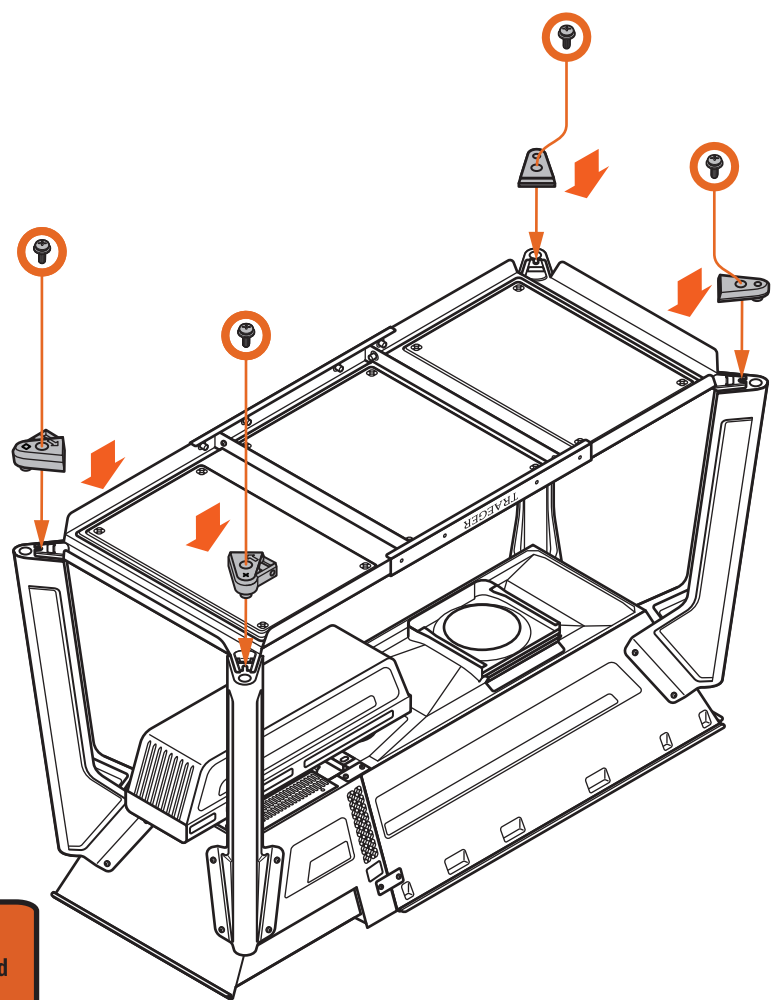
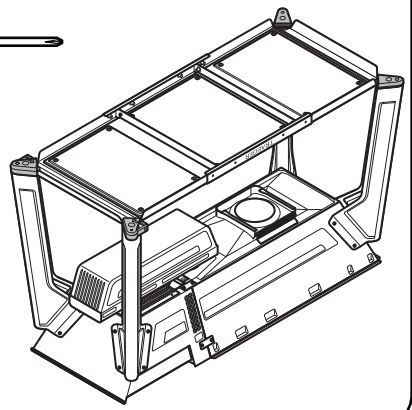
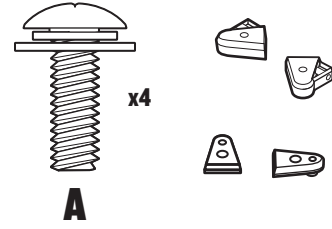

Use **THIS** screw again!



 **PRO TIP:** Make sure alignment and positioning of hooves is as shown.

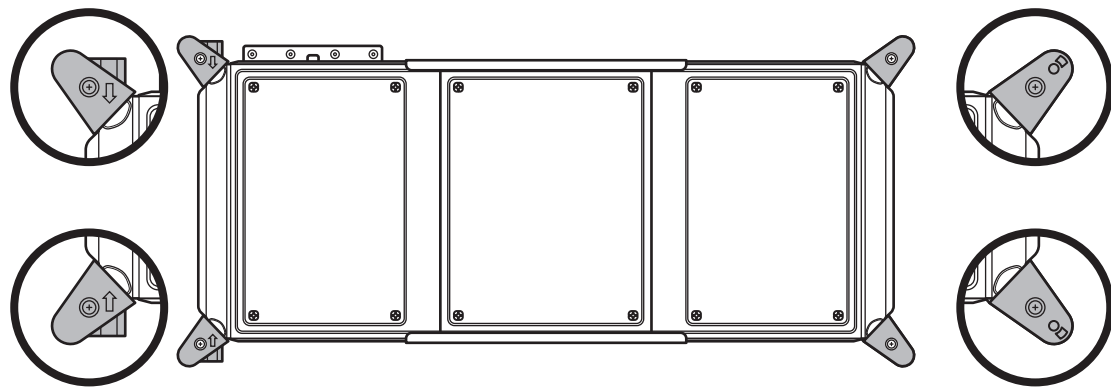



# 4 ASSEMBLE WHEELS & CASTERS

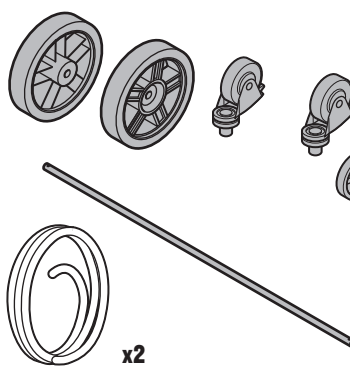

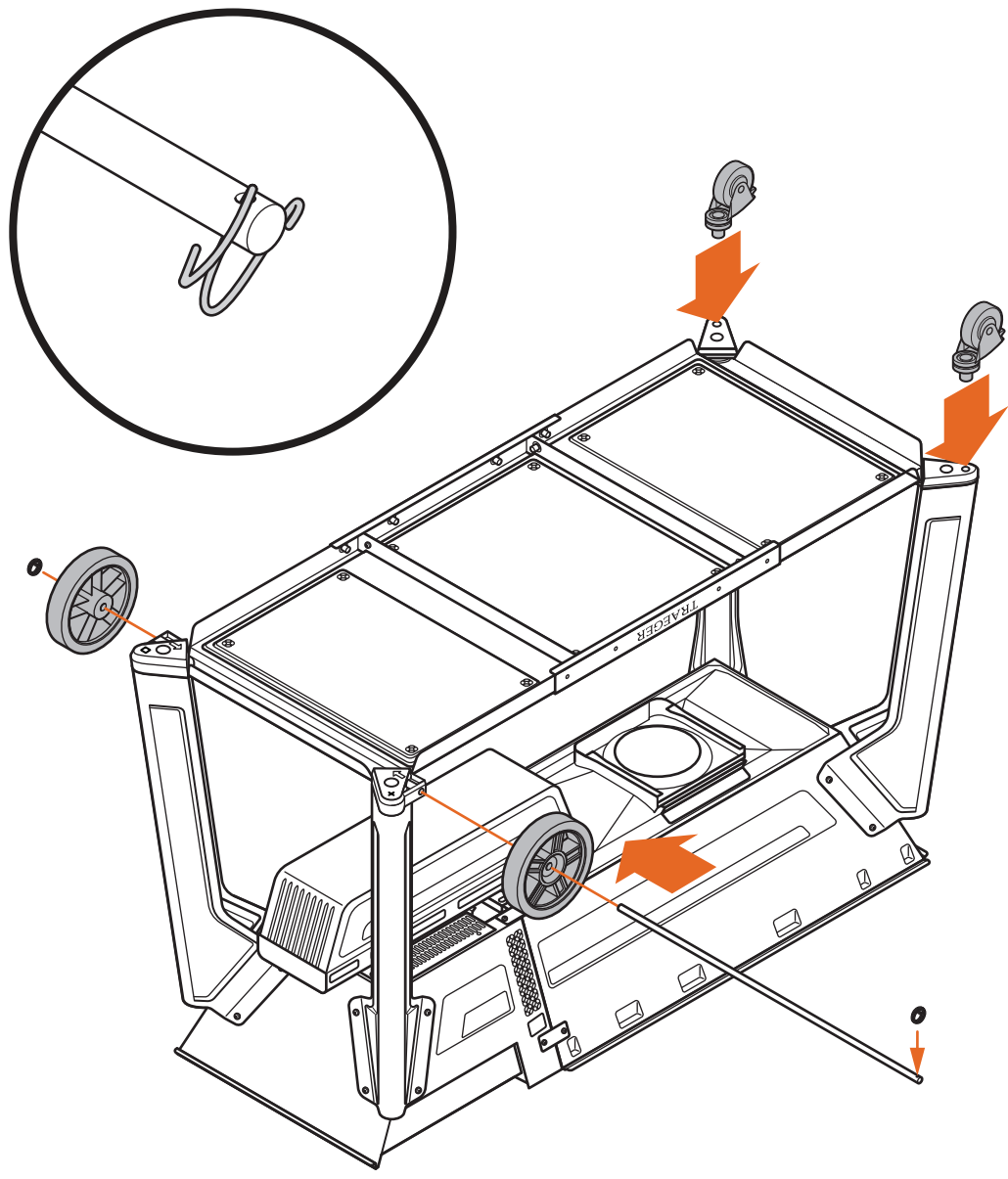

**D** x2



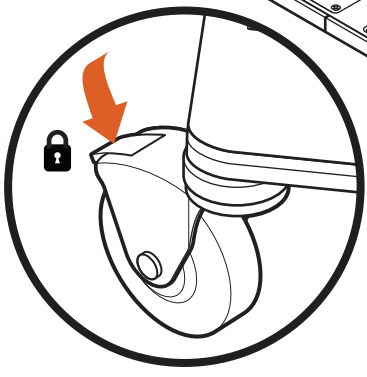
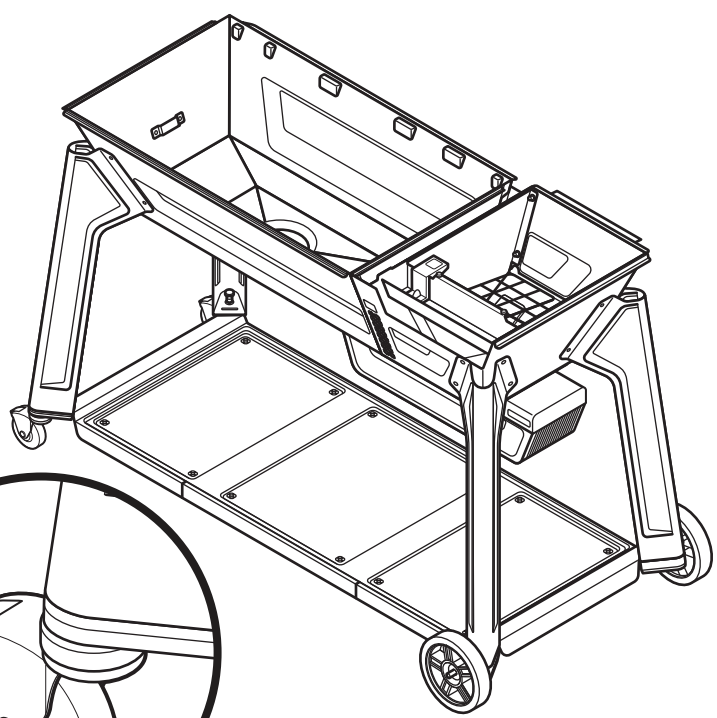
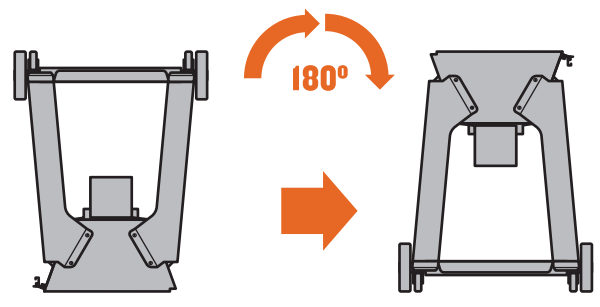
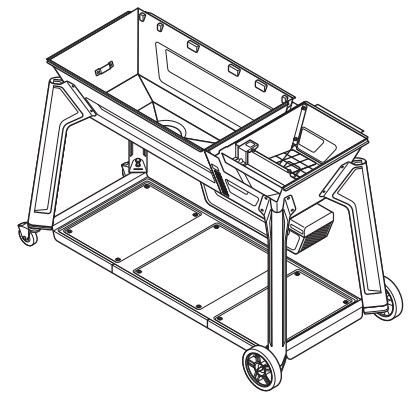

# 5 FLIP GRILL OVER



 **PRO TIP:** Lock casters to prevent grill from possibly rolling.

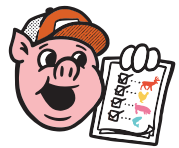

**NICE WORK!  
CHAPTER 2 COMPLETE!**

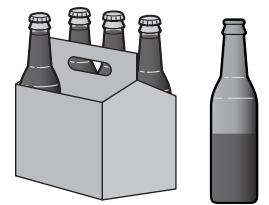



# CHAPTER 3

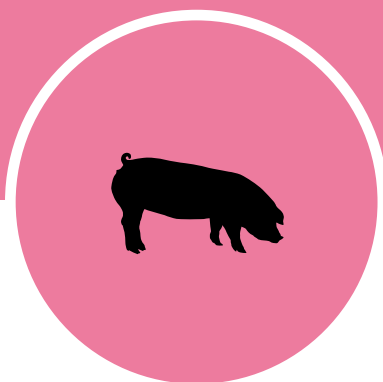
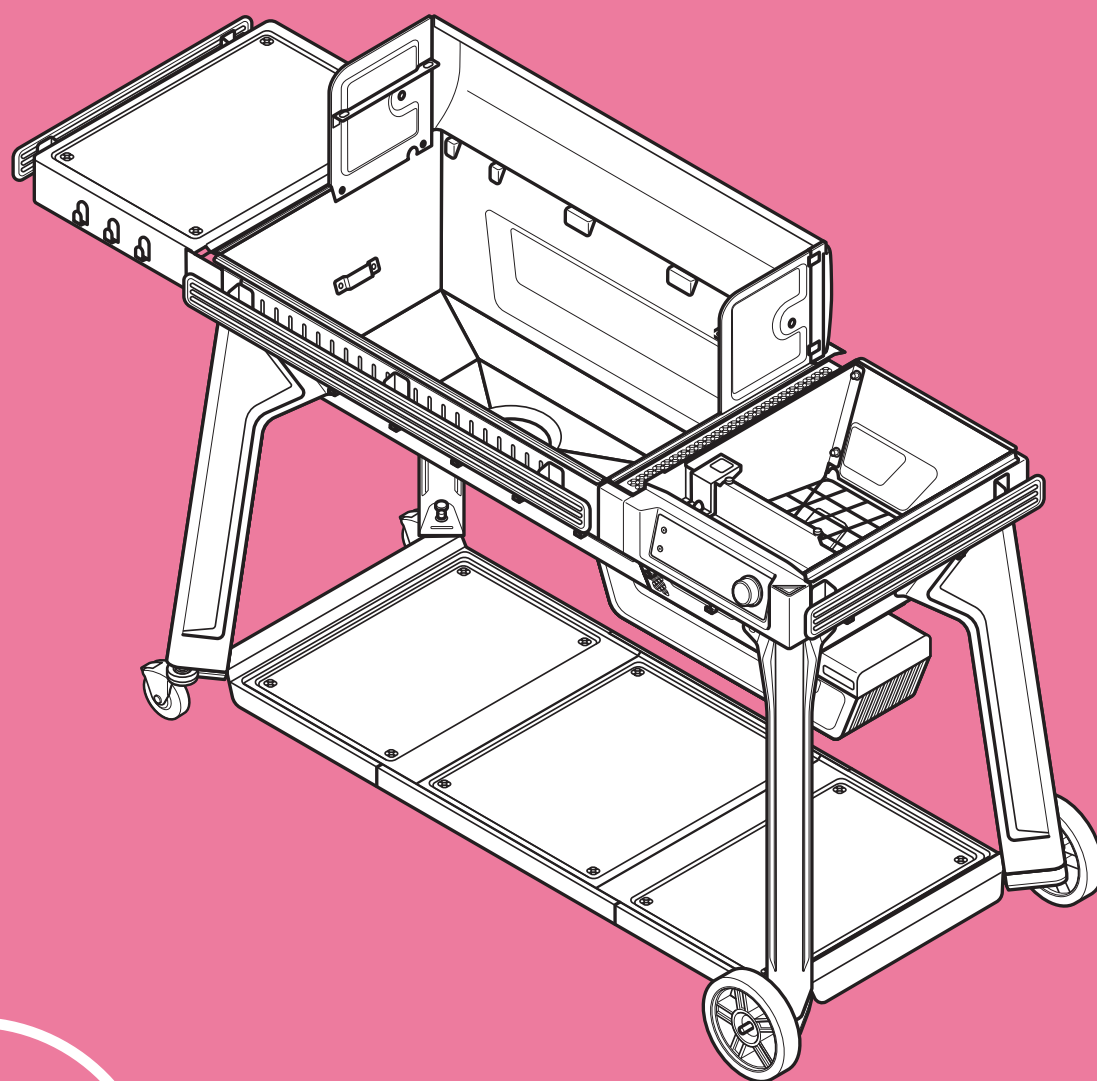

## CONTROLS & SHELVING



# CHAPTER 3

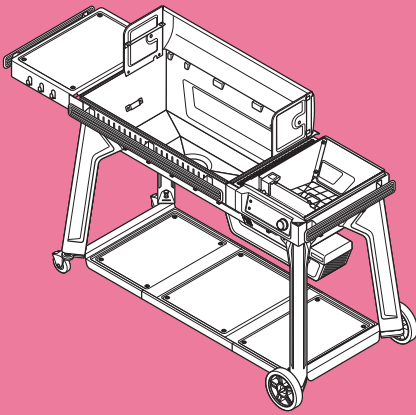

## 1 BUILD P.A.L. RAILS

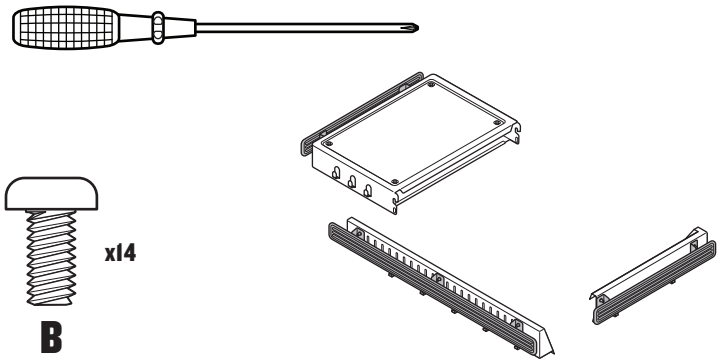

**PRO TIP:** Hand-tighten all screws first, then finish tightening with screwdriver.

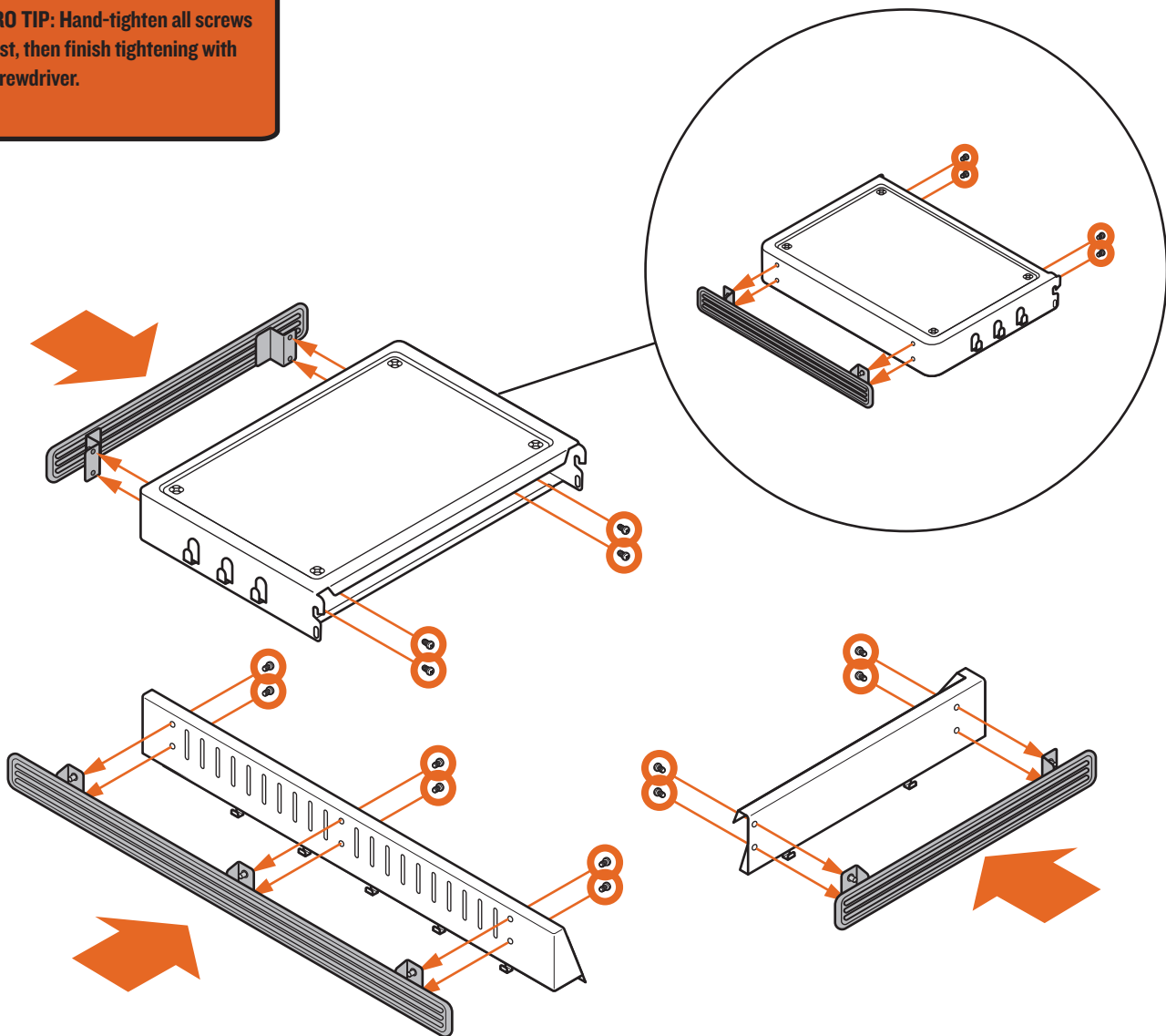



**PRO TIP:** This step can be tricky. Scan our QR code to access video animations for assembly. Jump to Chapter 3, Step 2 for a video.

**PRO TIP:** To prevent hardware from falling into the auger box, lay this manual on top of the grate.



## 2A ATTACH P.A.L. TRIM



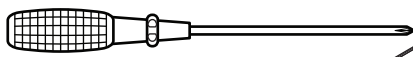
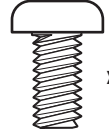

x6

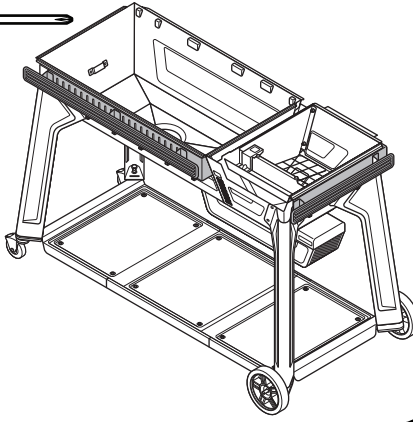
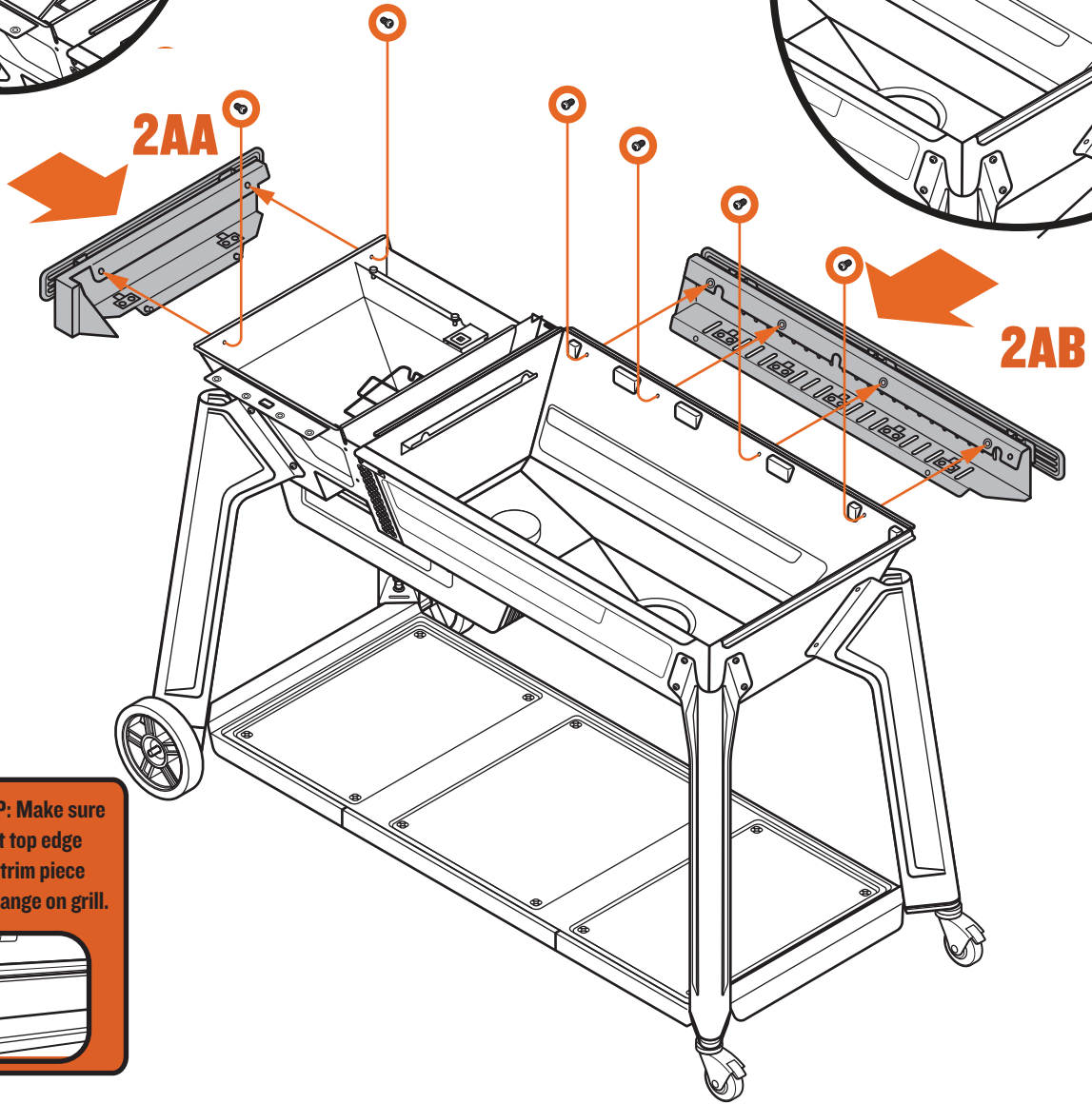
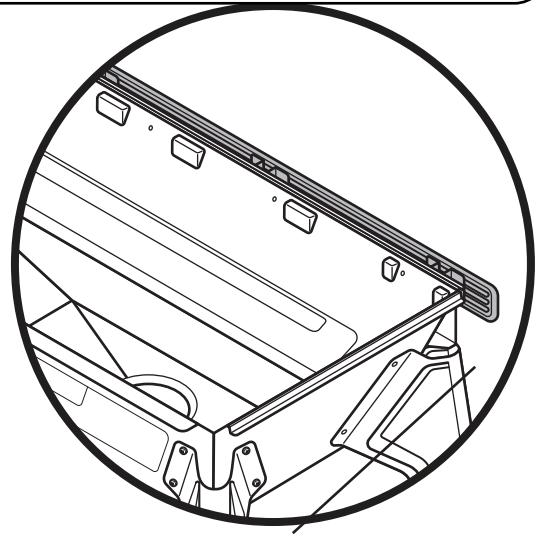
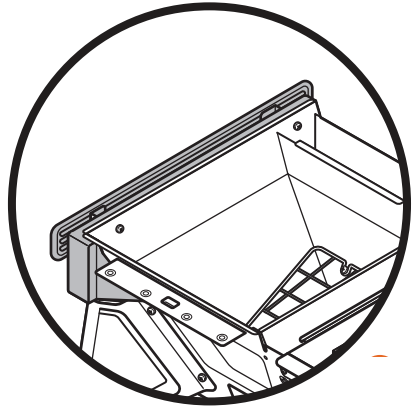
**B**



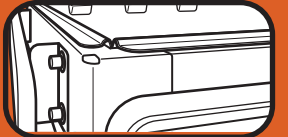

**PRO TIP:** Make sure to insert top edge of each trim piece under flange on grill.



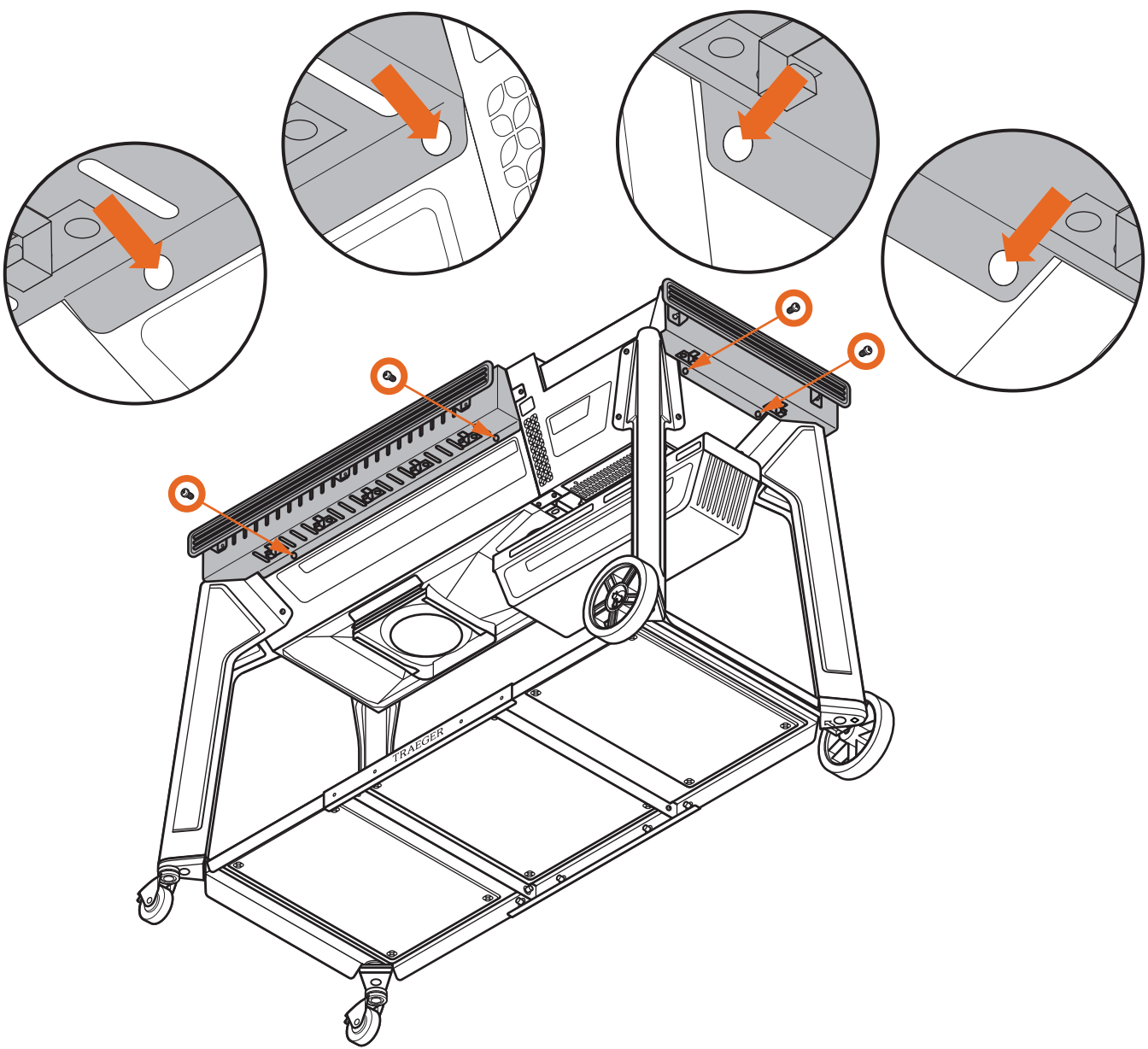
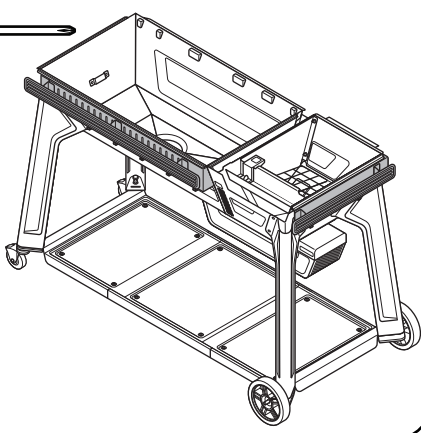
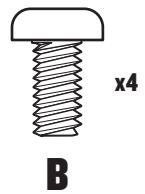
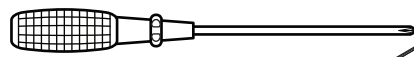

## 2B SECURE P.A.L. TRIM



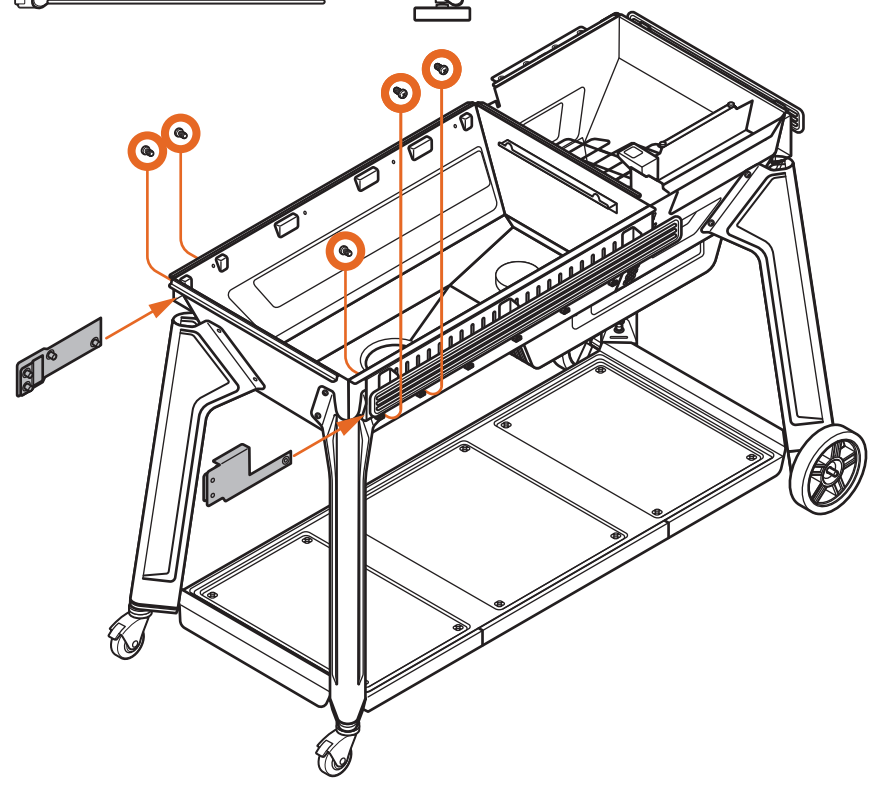
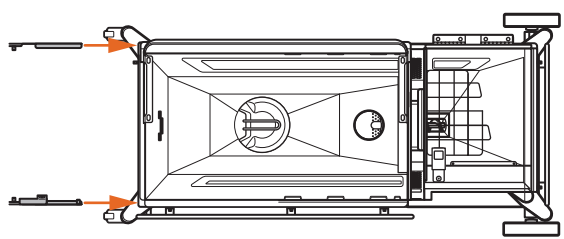
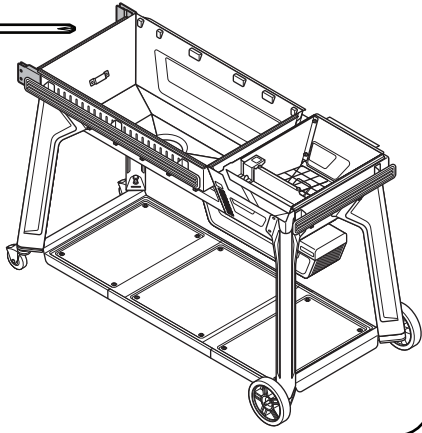
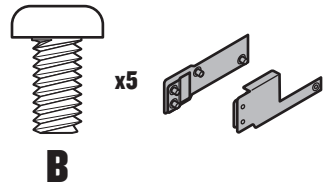
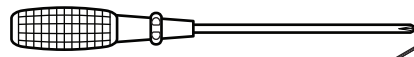

### 3A ATTACH FOLDING SIDE SHELF





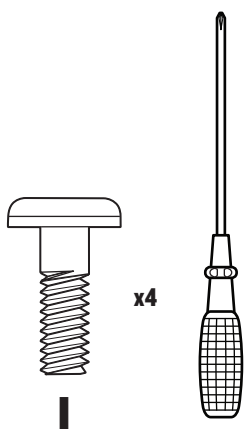

**PRO TIP:** Hand-tighten all screws first, then finish tightening with screwdriver.

## 3B ATTACH FOLDING SIDE SHELF

x4

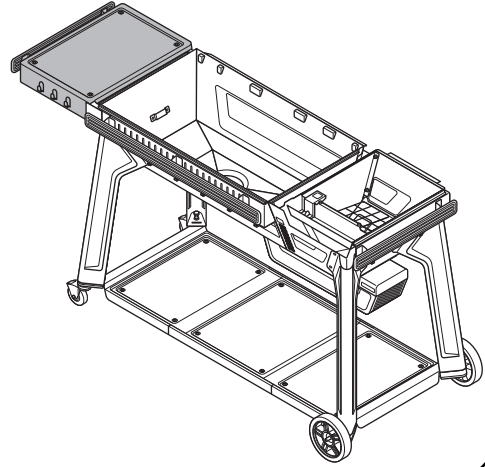
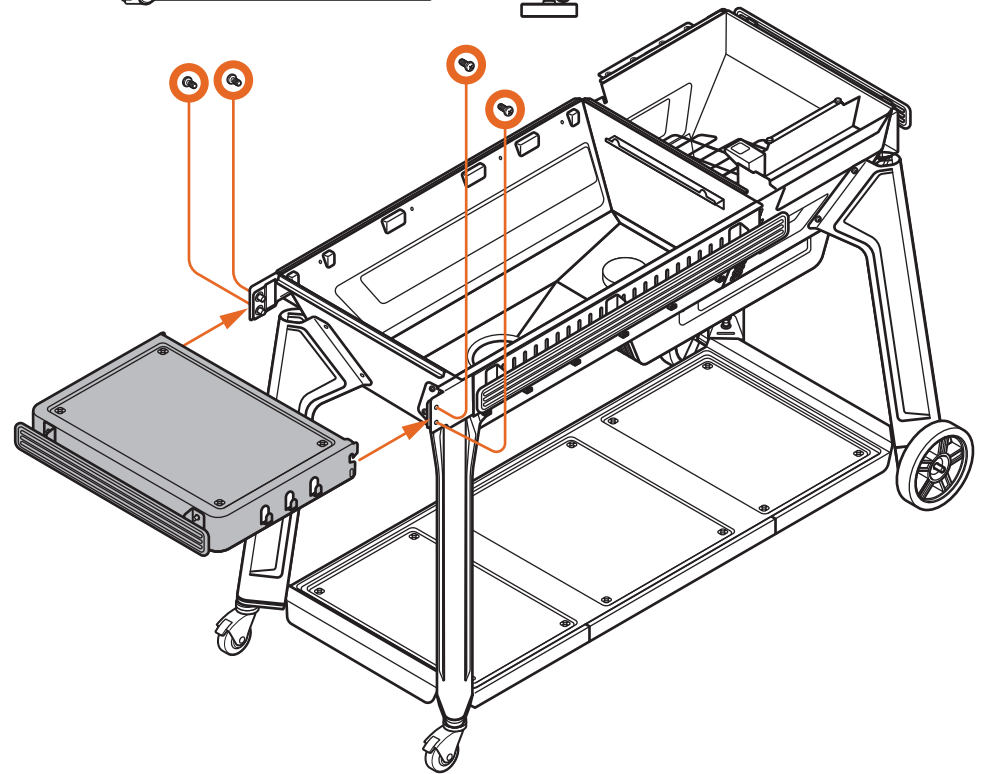
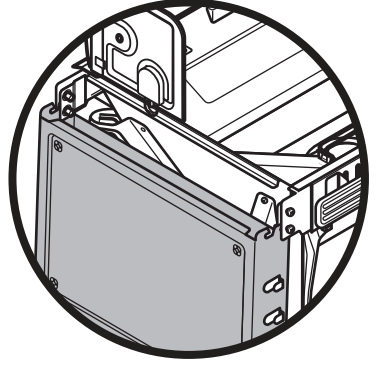
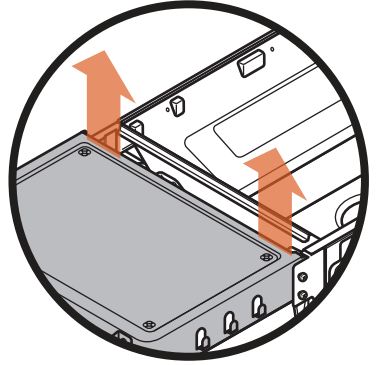
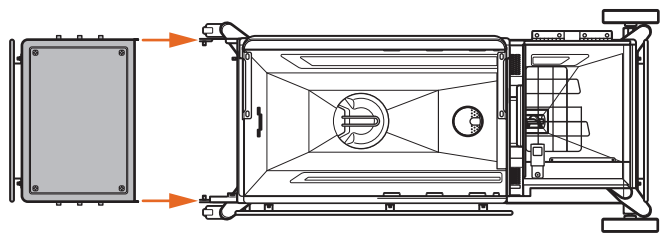



**PRO TIP:** This step requires no hardware.

# 4 ASSEMBLE BACKSPLASH

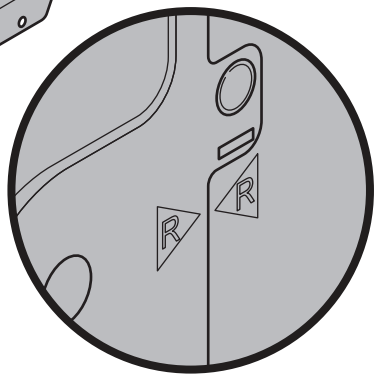
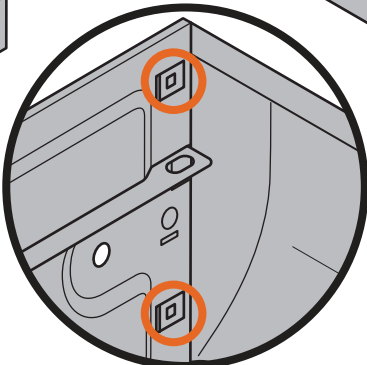
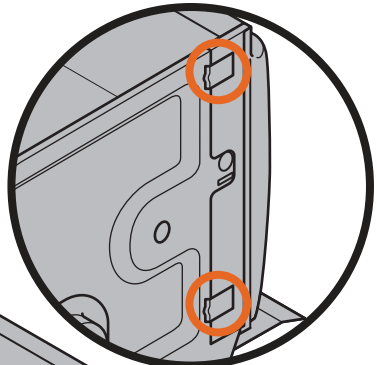
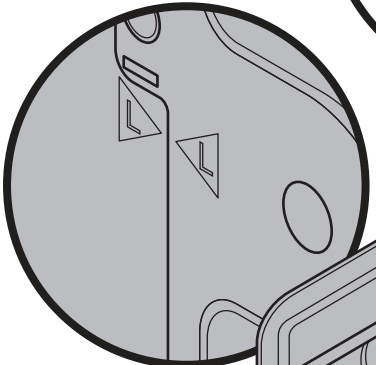
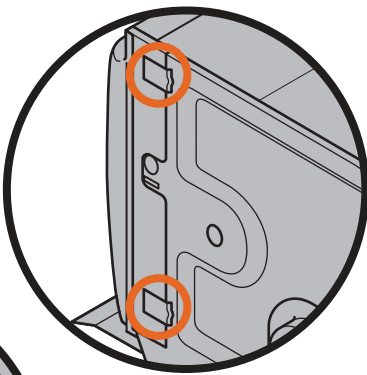
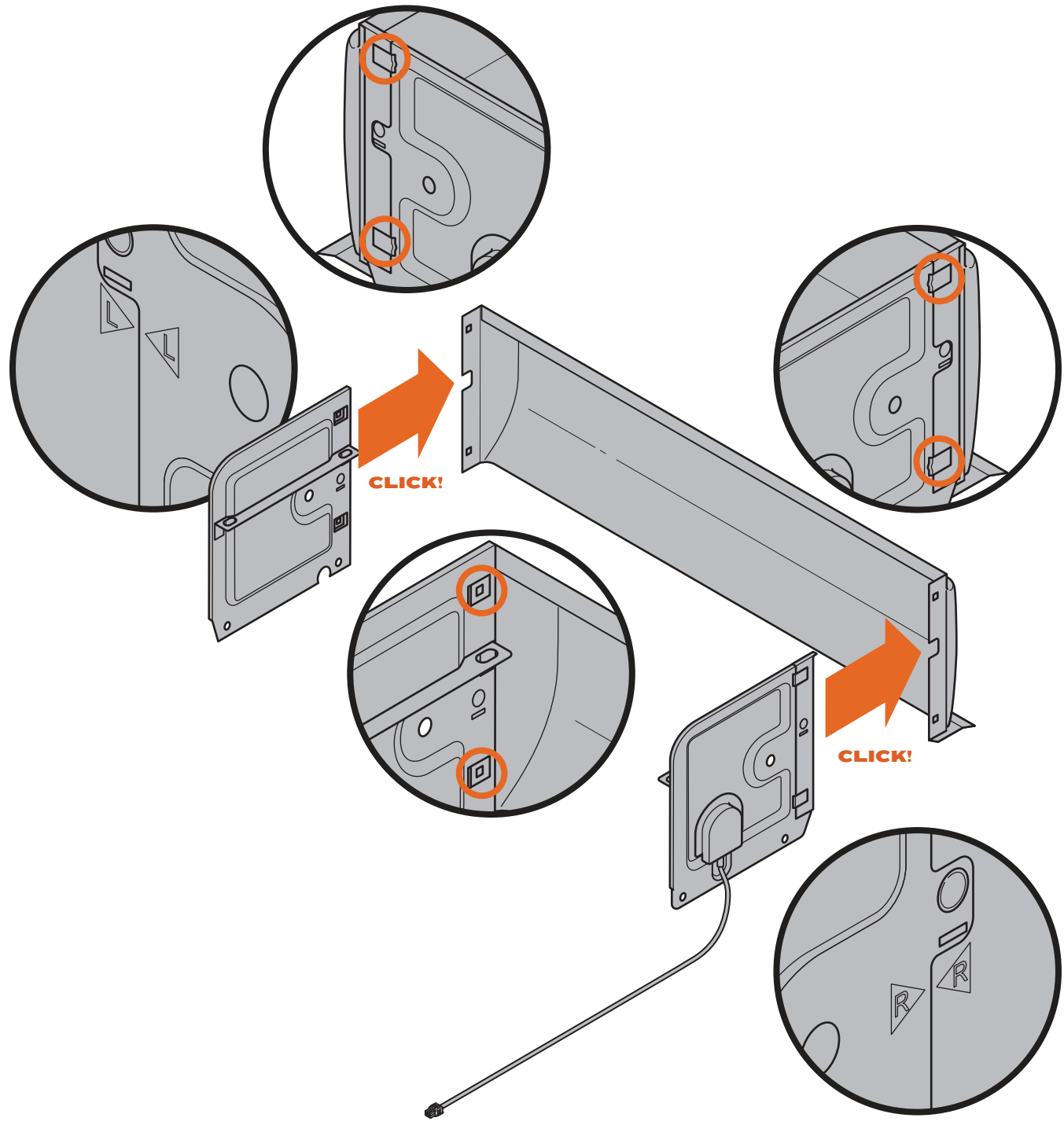

 **PRO TIP:** Don't pinch the wire between the backsplash and the grill body! Also, slide the wire through the openings carefully to prevent damage!

## 5 ROUTE BACKSPLASH WIRING



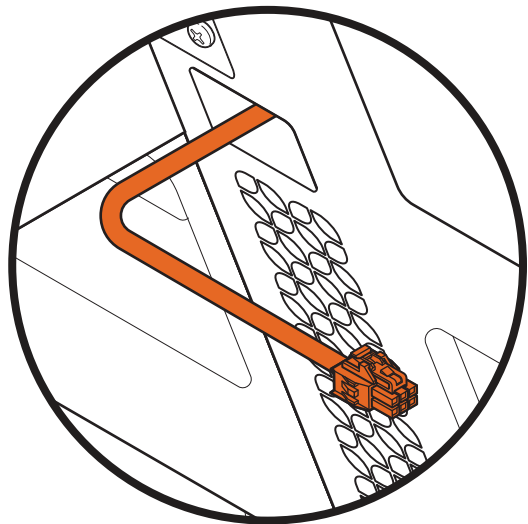
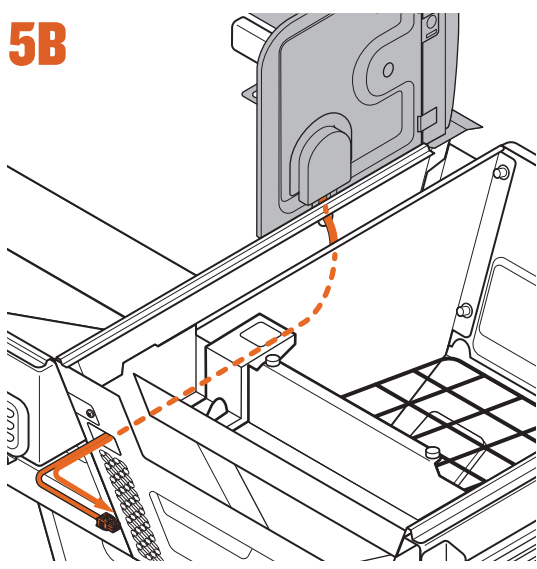
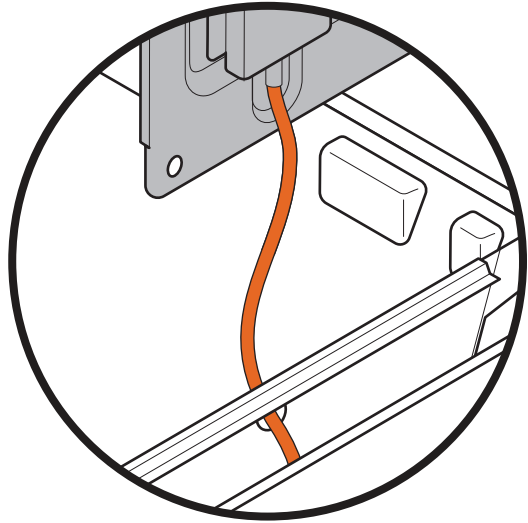
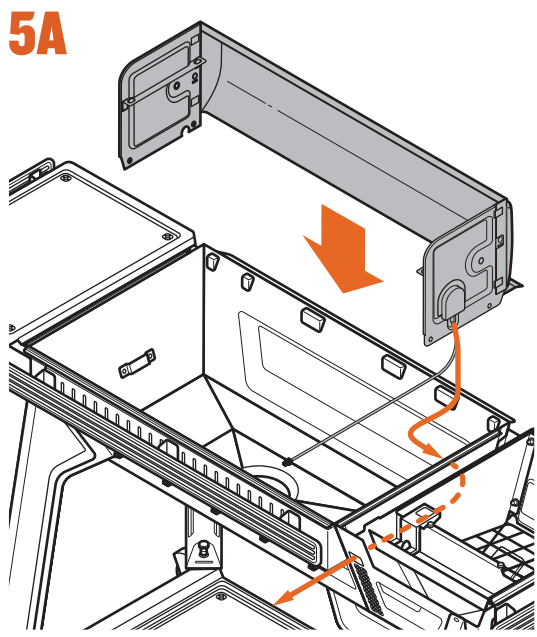
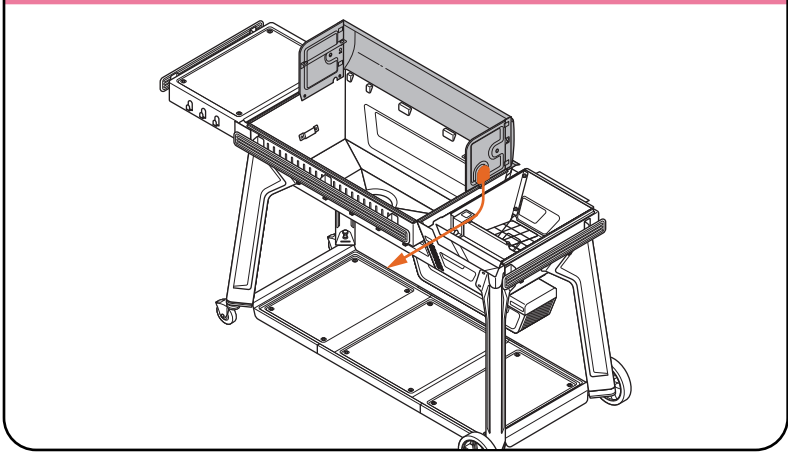

# 6 ATTACH BACKSPLASH

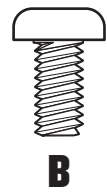

x4

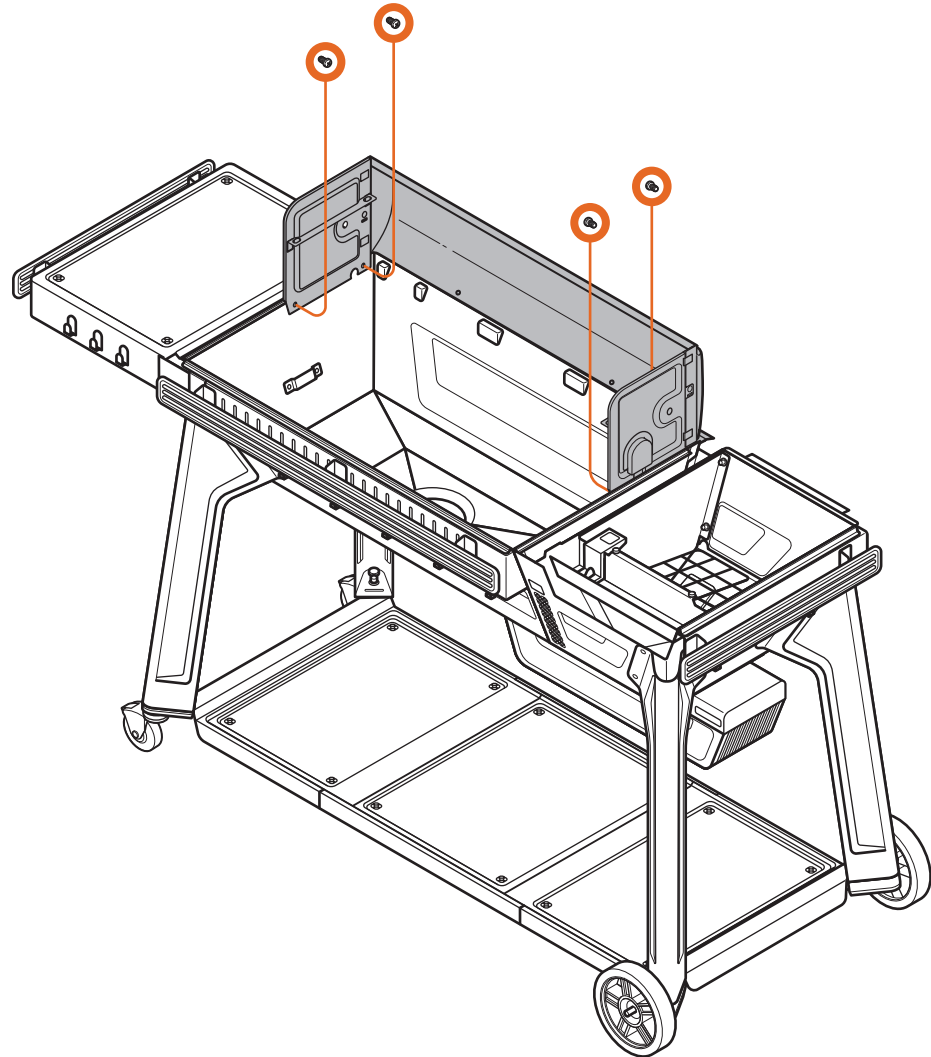
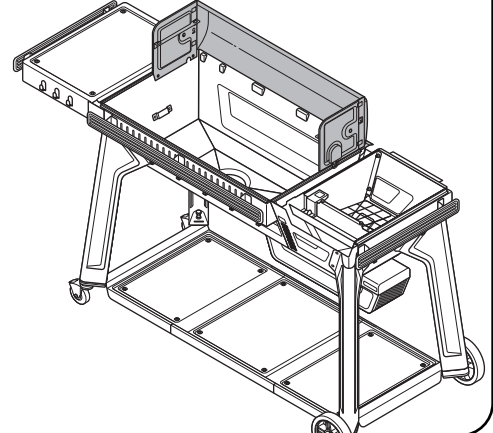
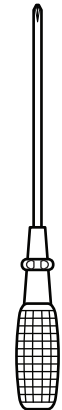



# 7 INSTALL REAR HOOK

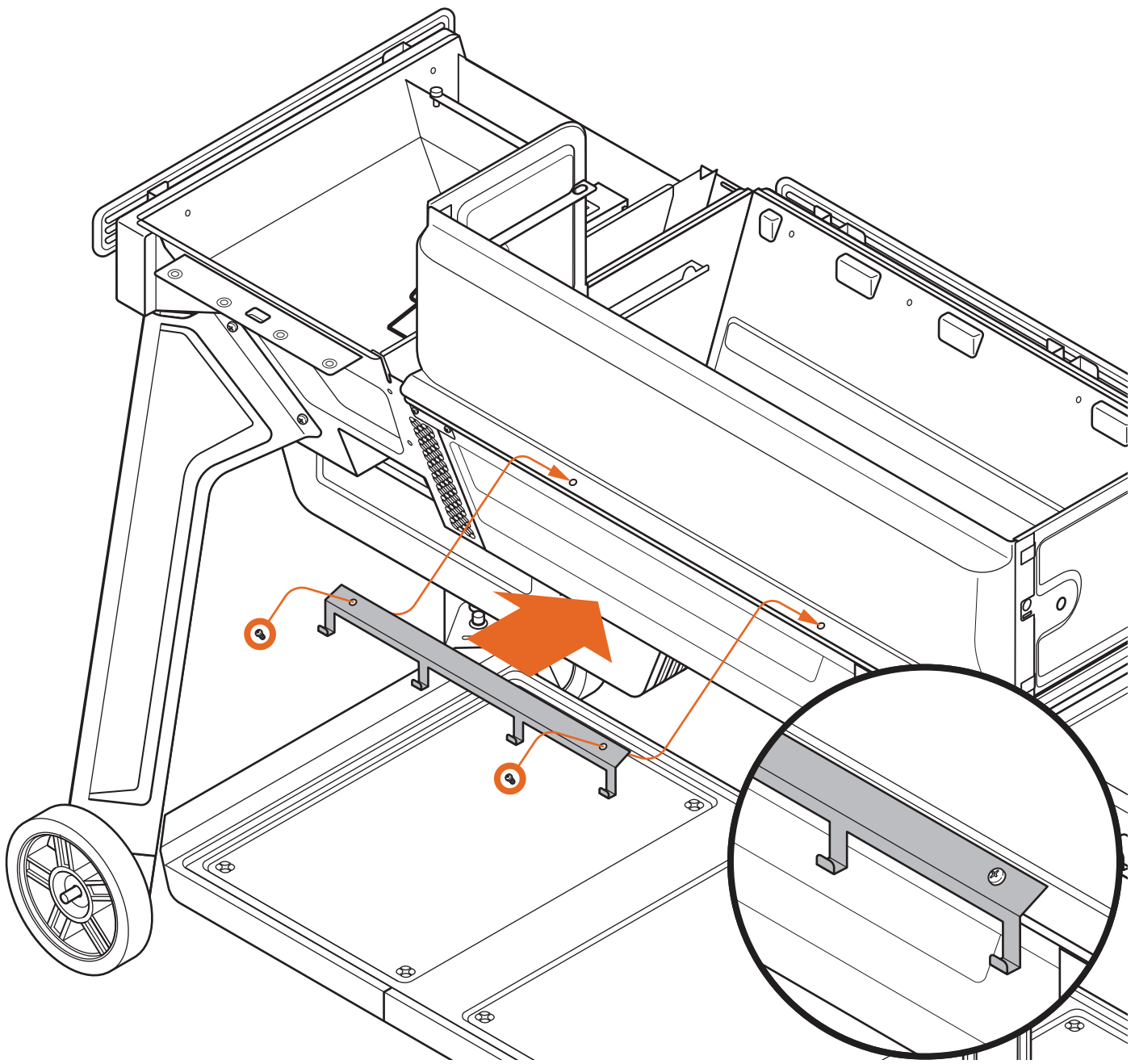
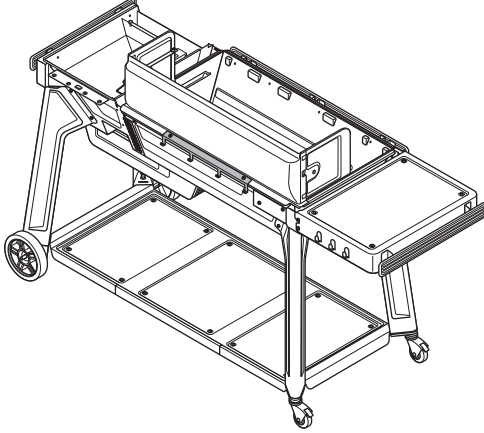
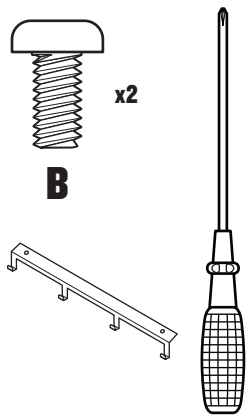





# 8 CONNECT CONTROLLER

RTD SENSOR  
4-PIN  
CONNECTOR

CONTROLLER  
12-PIN  
CONNECTOR

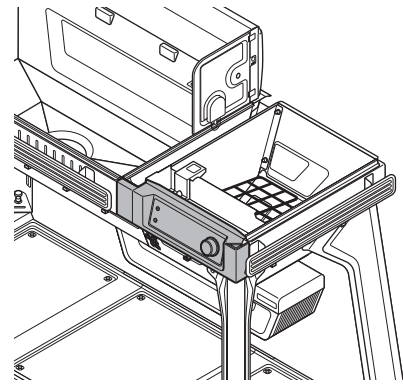
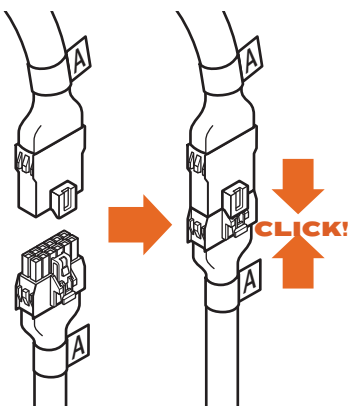
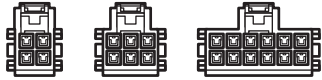
PELLET LEVEL  
SENSOR 6-PIN  
CONNECTOR



 **PRO TIP:** For easier connecting, lay the controller on its back on the edge of the hopper.

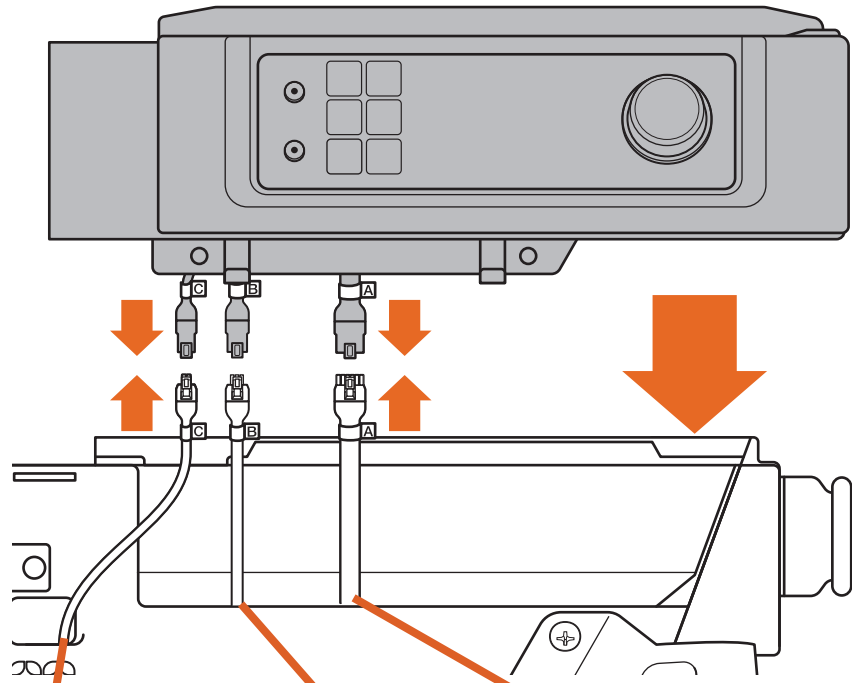
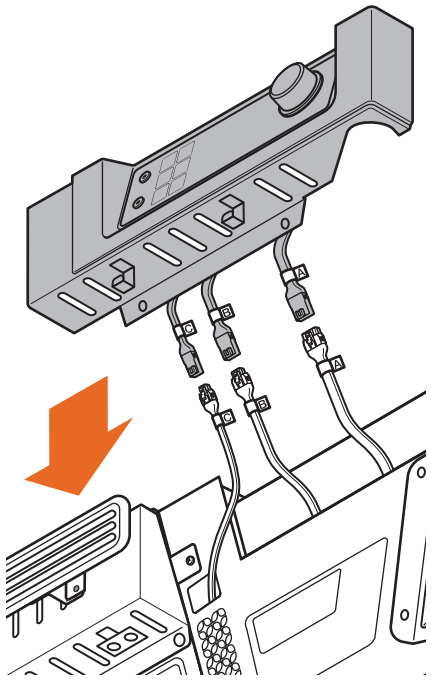

RTD SENSOR  
4-PIN  
CONNECTOR

PELLET LEVEL  
SENSOR 6-PIN  
CONNECTOR

CONTROLLER  
12-PIN  
CONNECTOR



 **PRO TIP:** After connecting, tuck wires back into grill to prevent pinching them.

 **PRO TIP:** To more easily connect connector B, cut the zip tie holding it to the grill.





 **PRO TIP:** Install controller over flange in hopper.

# 9A ATTACH CONTROLLER

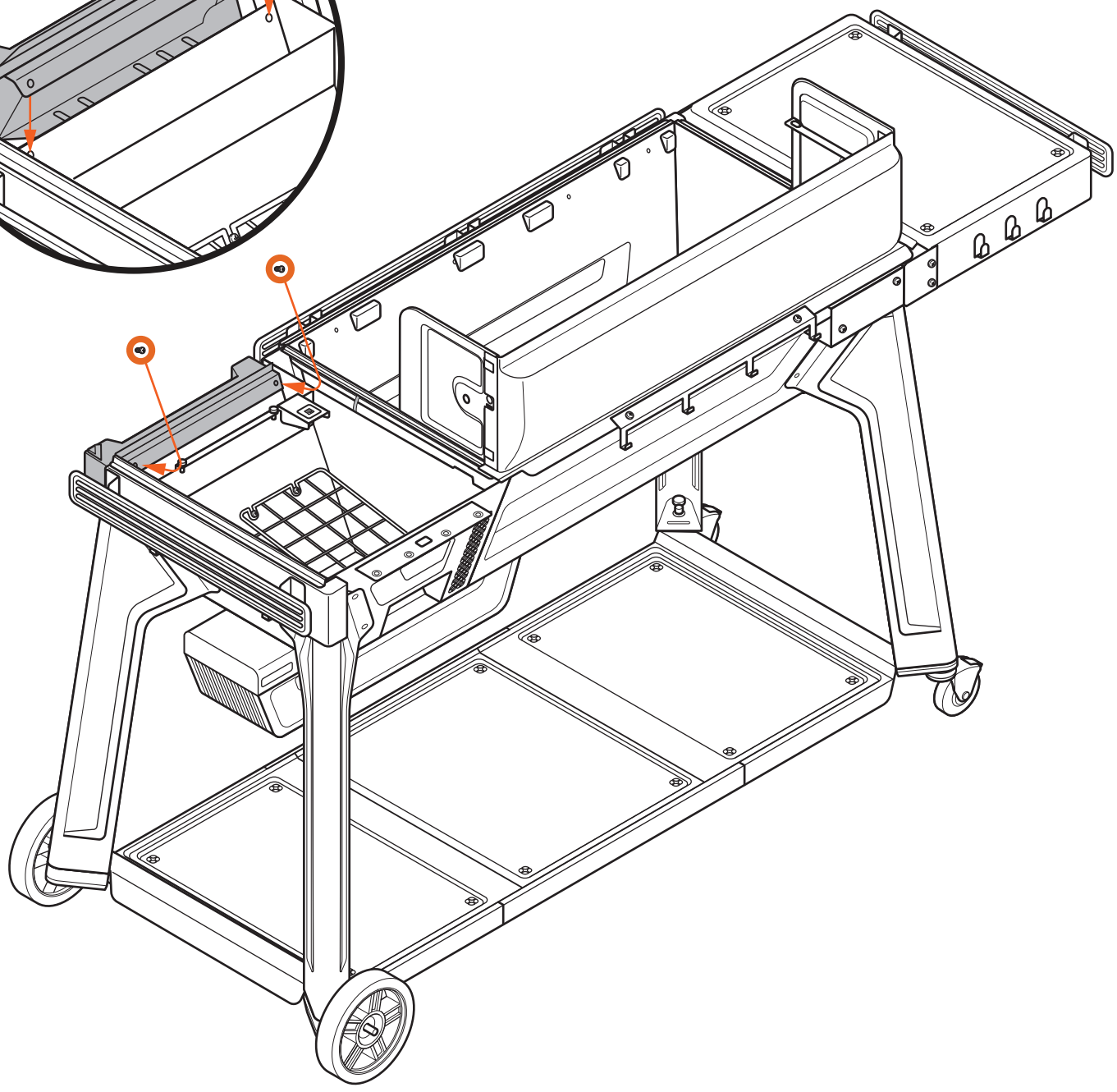
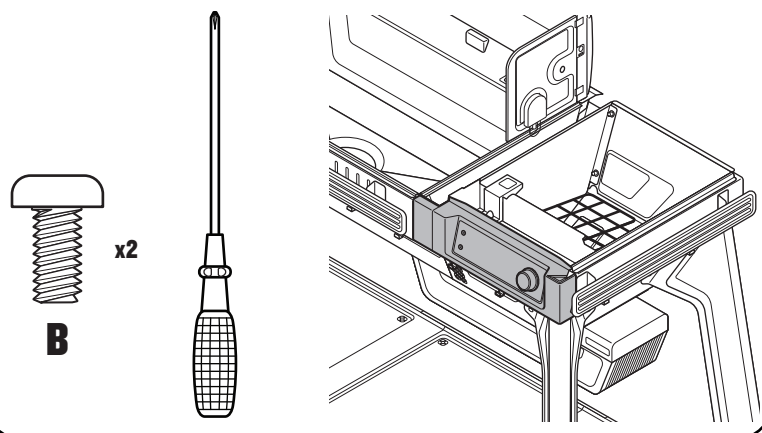
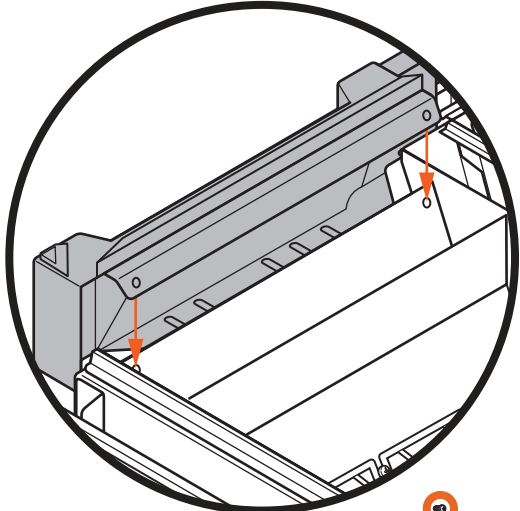



# 9B ATTACH CONTROLLER

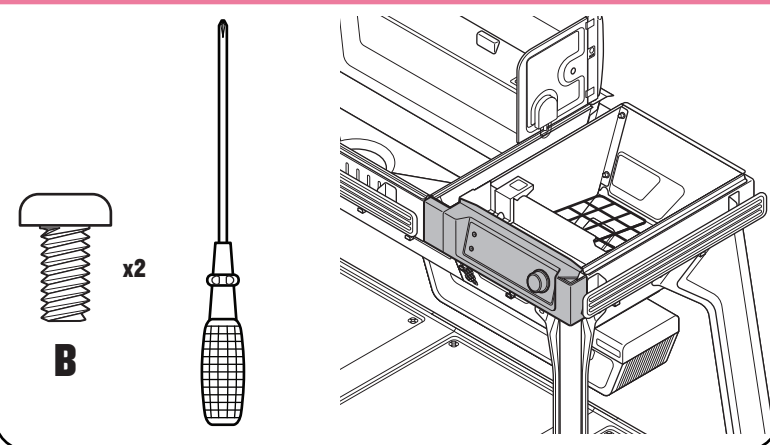

**B** x2

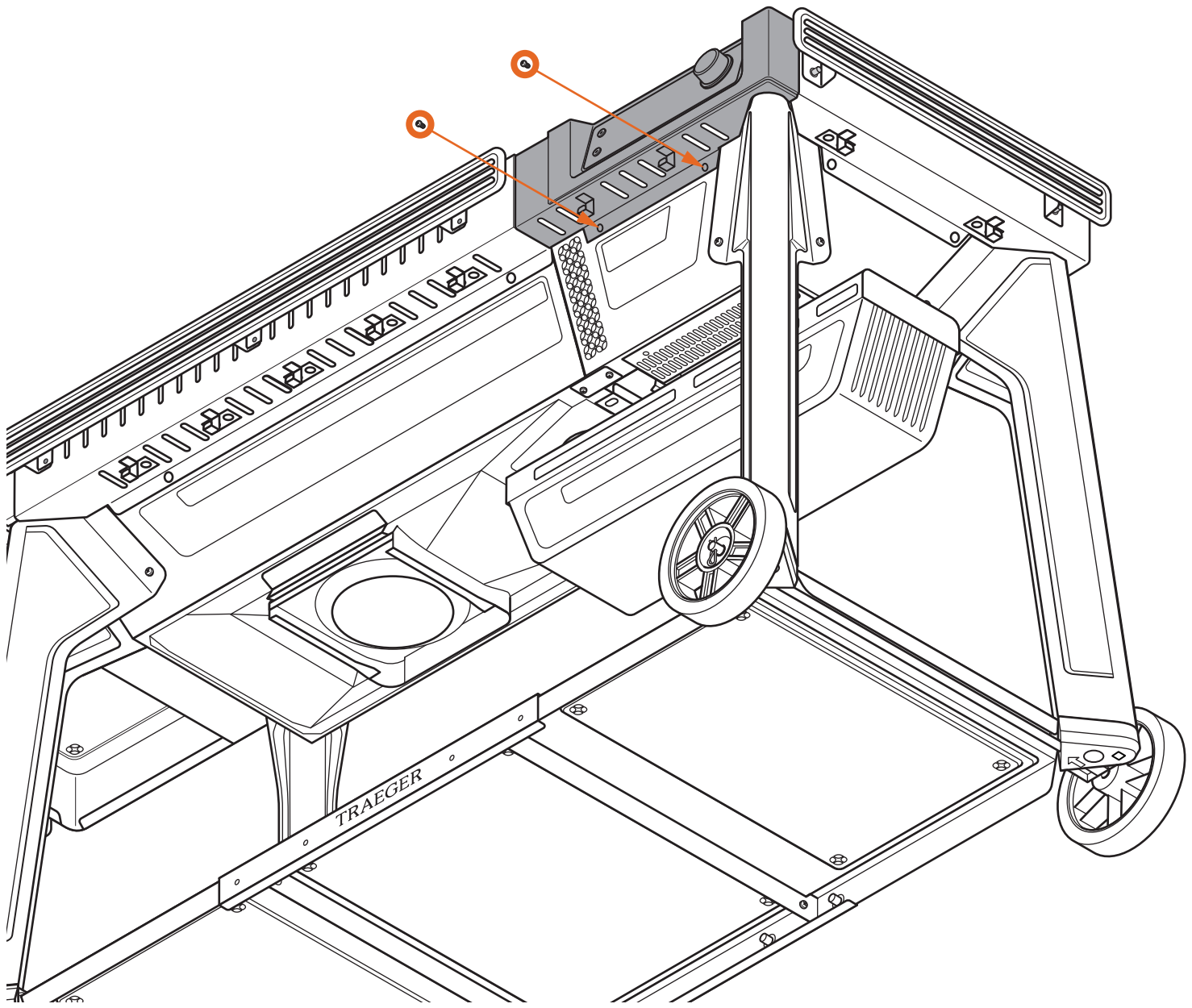

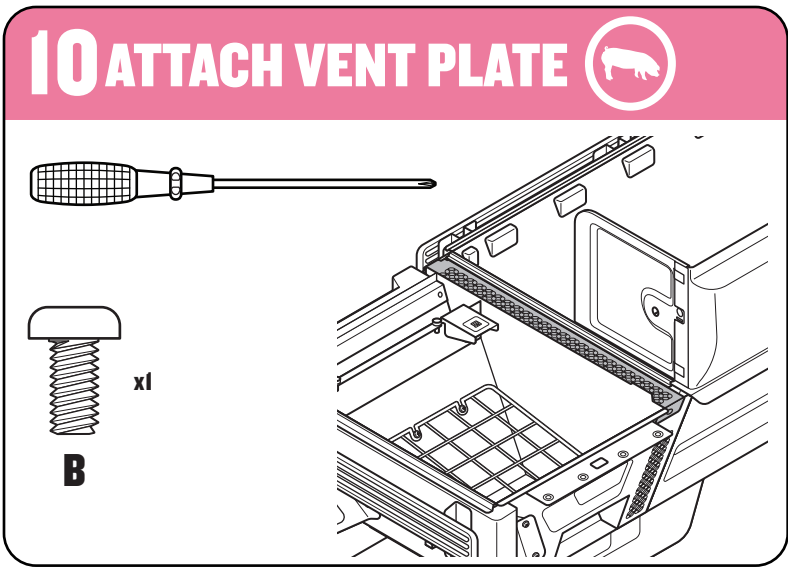

**10A**

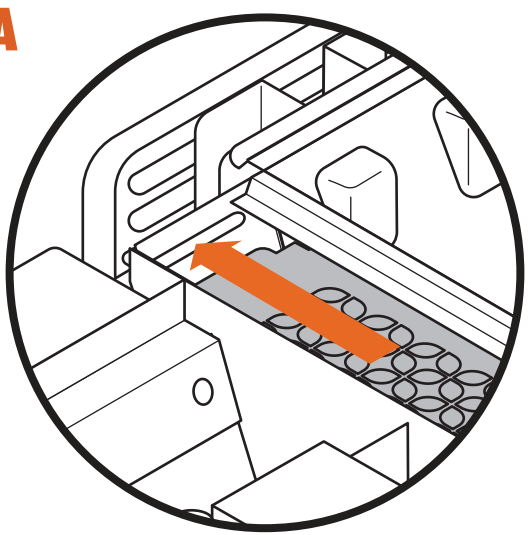

**10B**

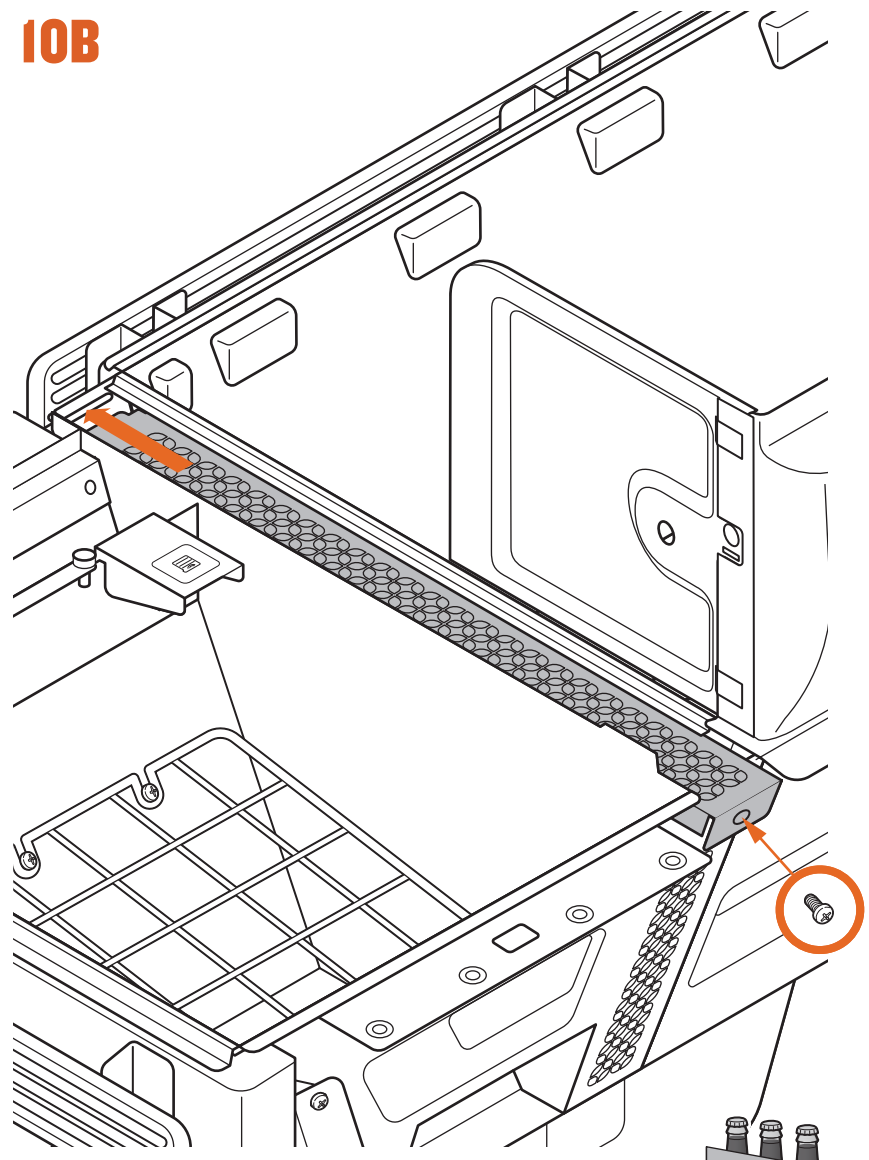

**NICE WORK!  
CHAPTER 3 COMPLETE!**

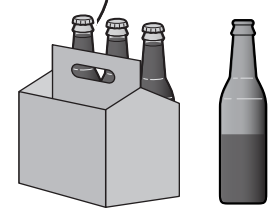

# CHAPTER 4

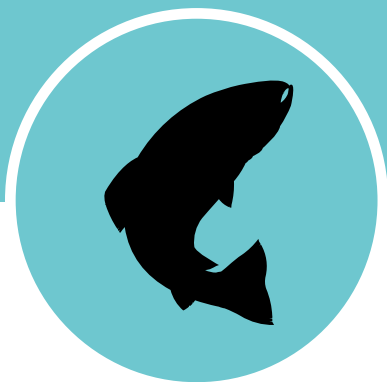
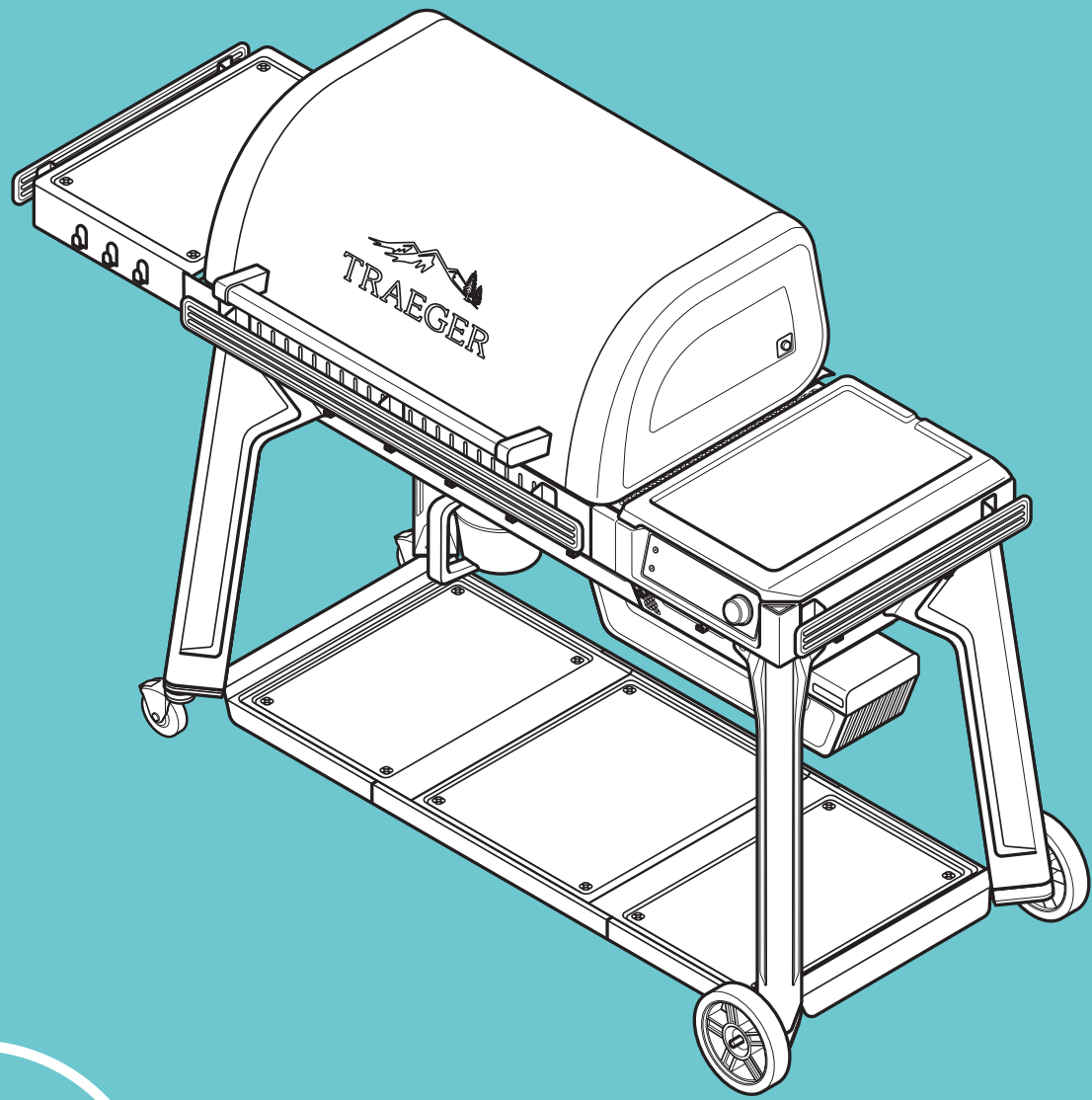

## LID & GRILL INTERNALS

# CHAPTER 4

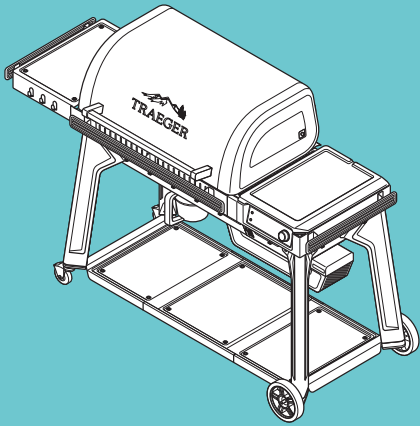

## 1 ATTACH HOPPER LID

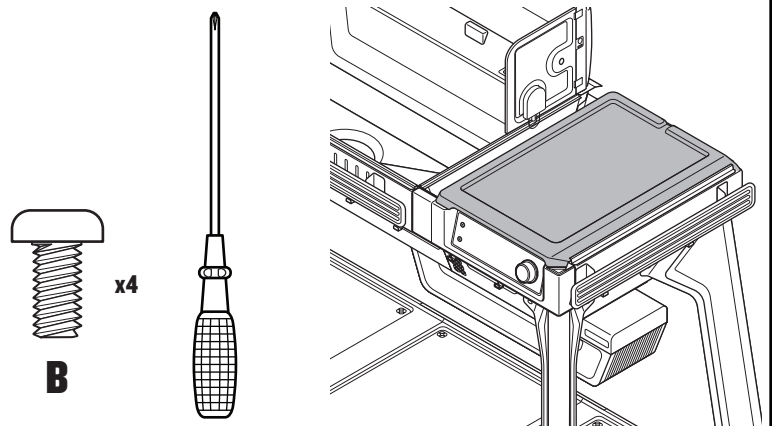

**PRO TIP:** Hand-tighten all screws first, then finish tightening with screwdriver.

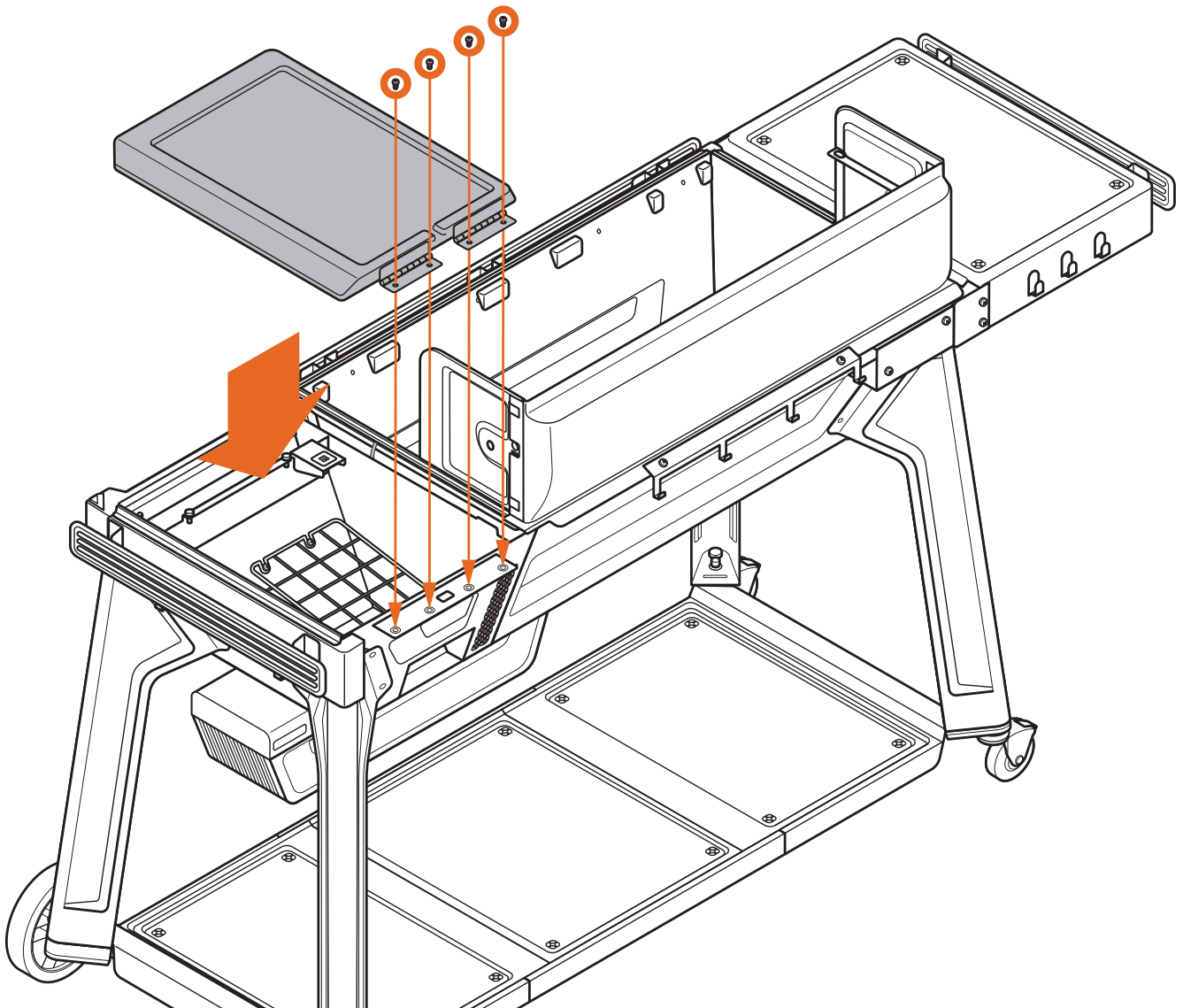



## 2 INSTALL CHUTE, SHIELD, AND BAFFLE

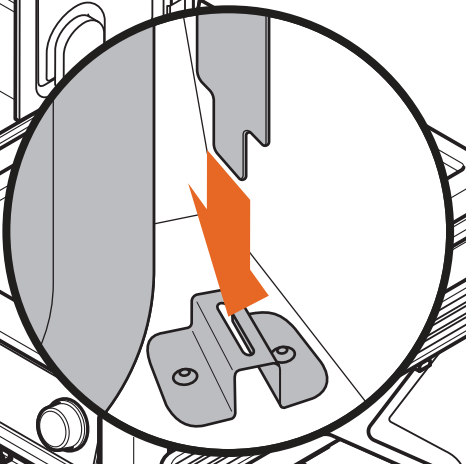
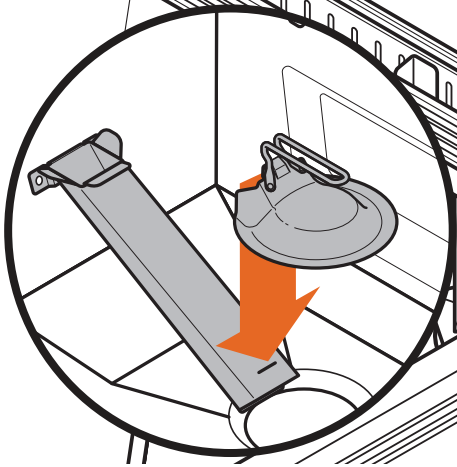
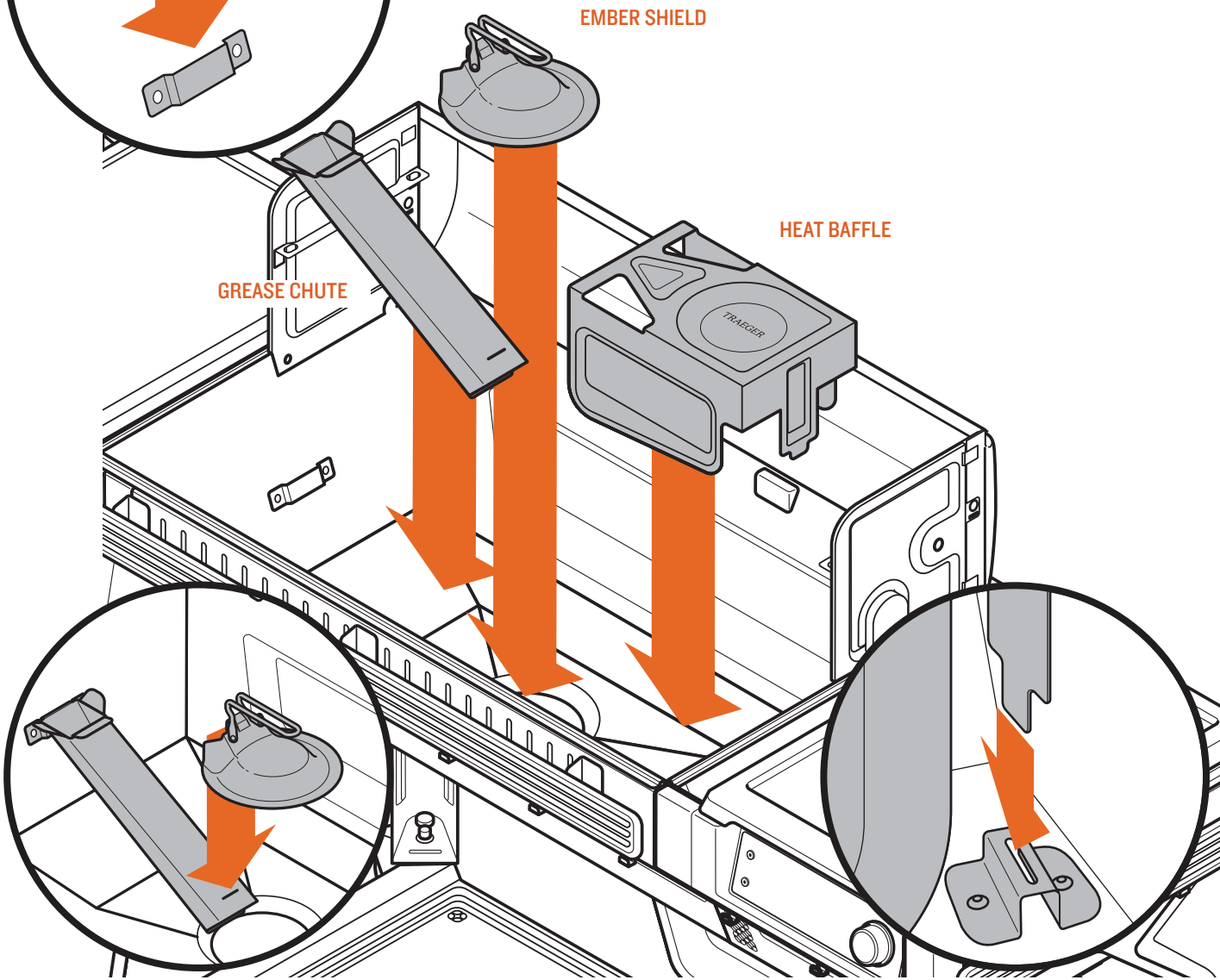
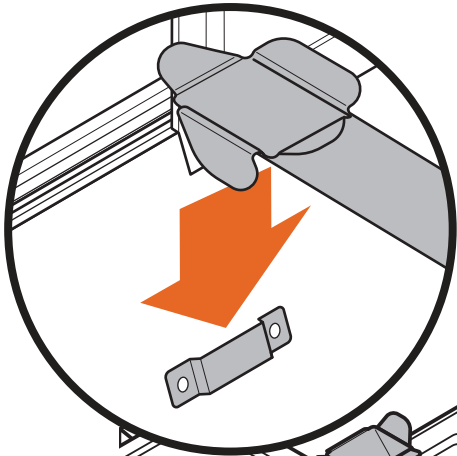
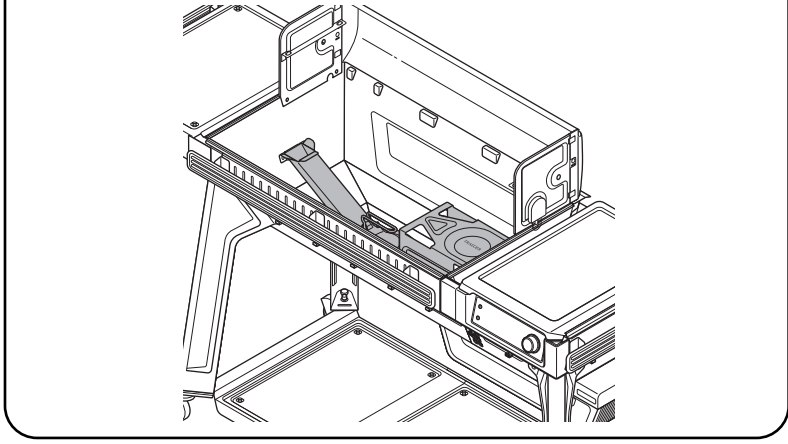
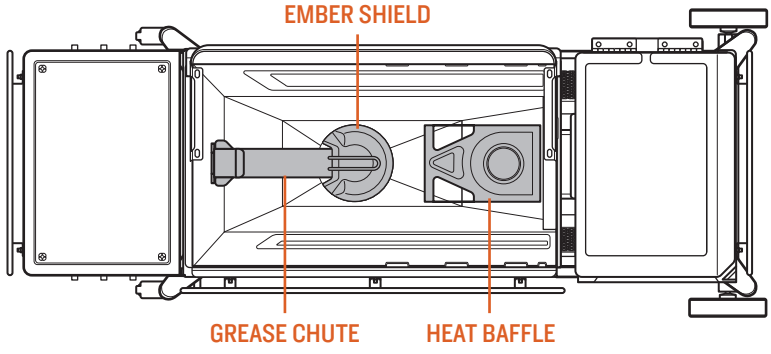



### 3 INSTALL DRIP TRAY

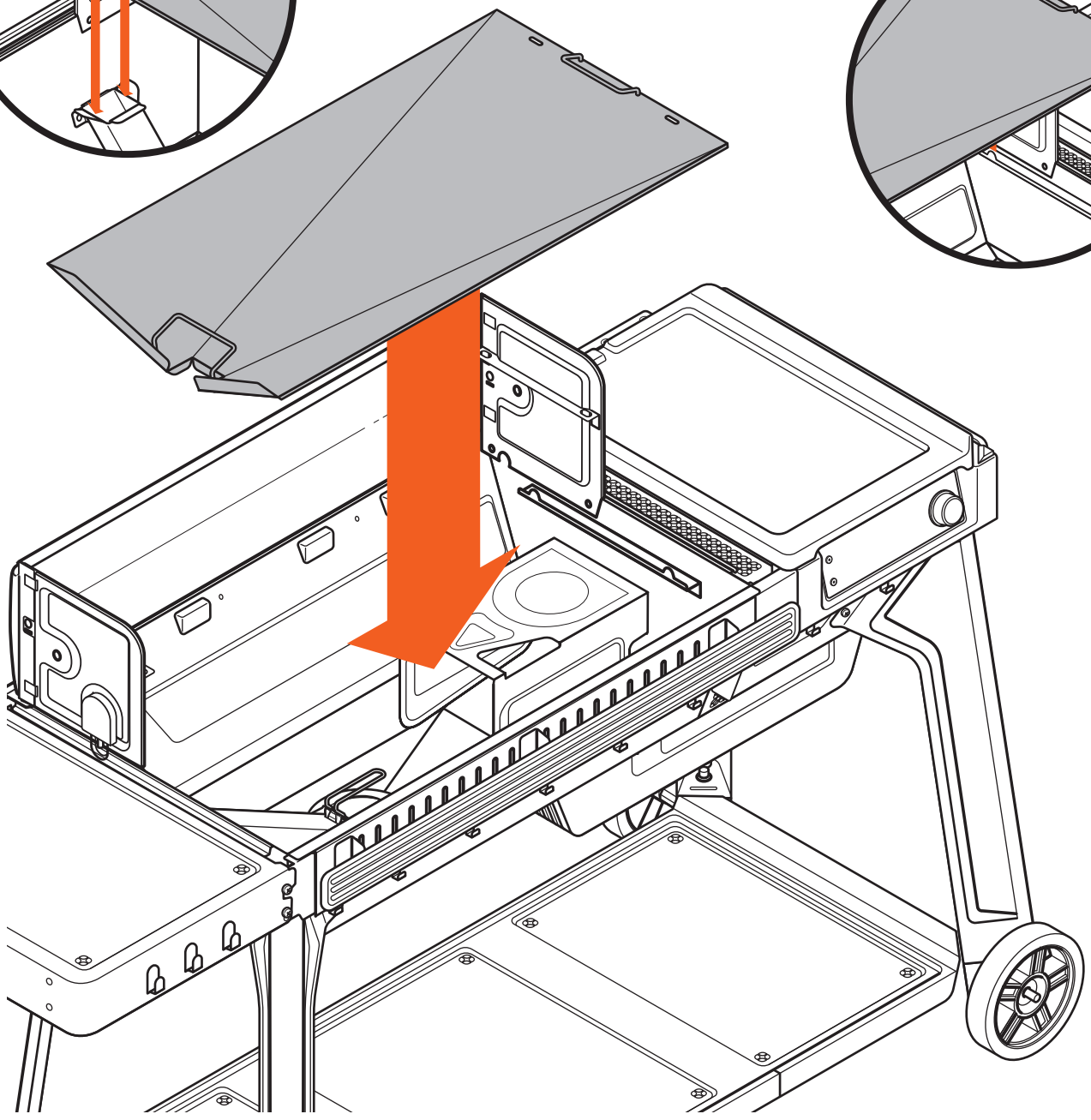
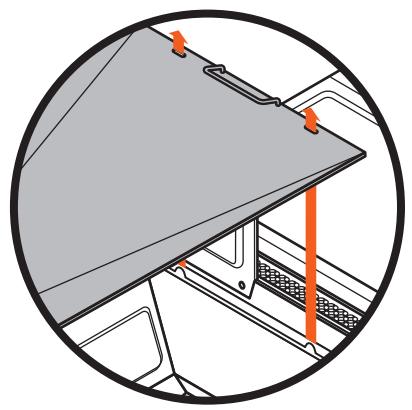
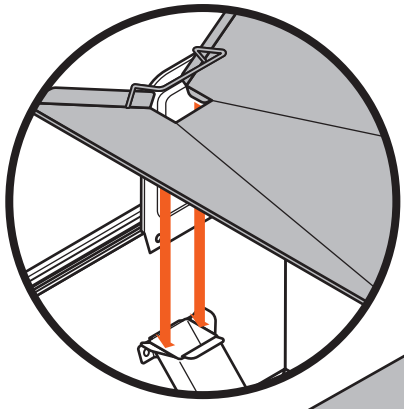
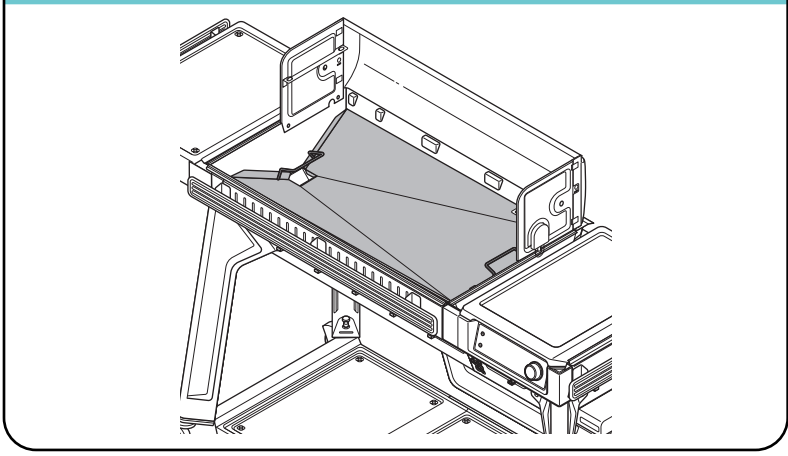



# 4A ATTACH LID HANDLE

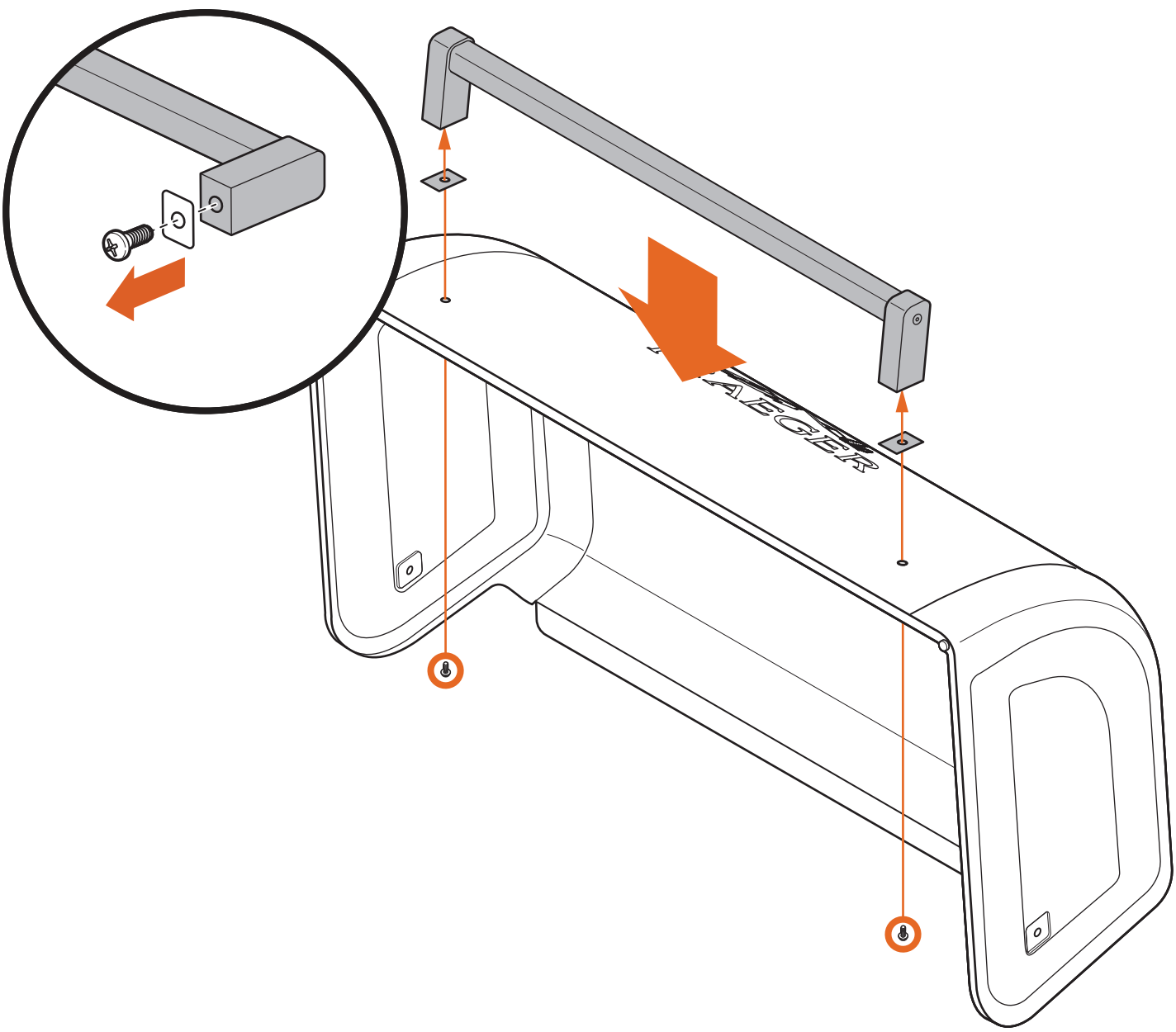
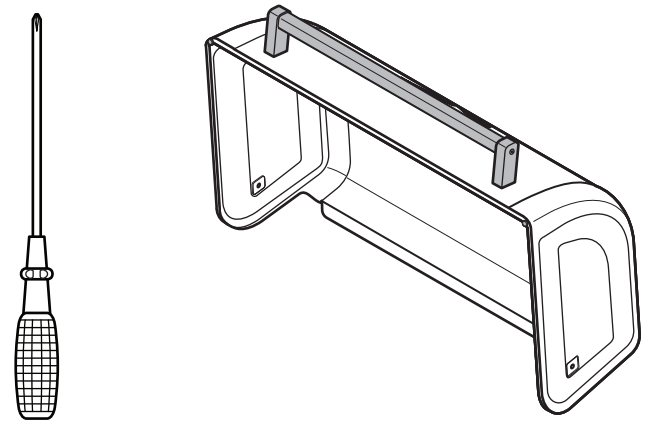



 **PRO TIP:** Use two people to attach the lid.

# 4B ATTACH LID

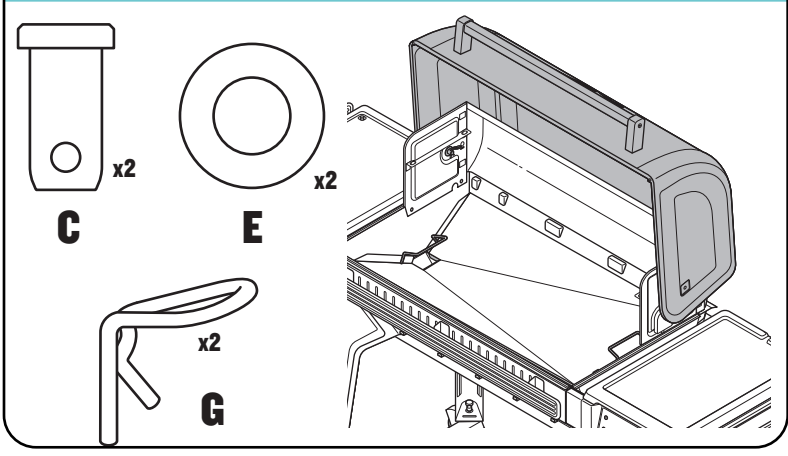

 **PRO TIP:** Attach hinge pins C with lid closed, then open lid to install E and G.

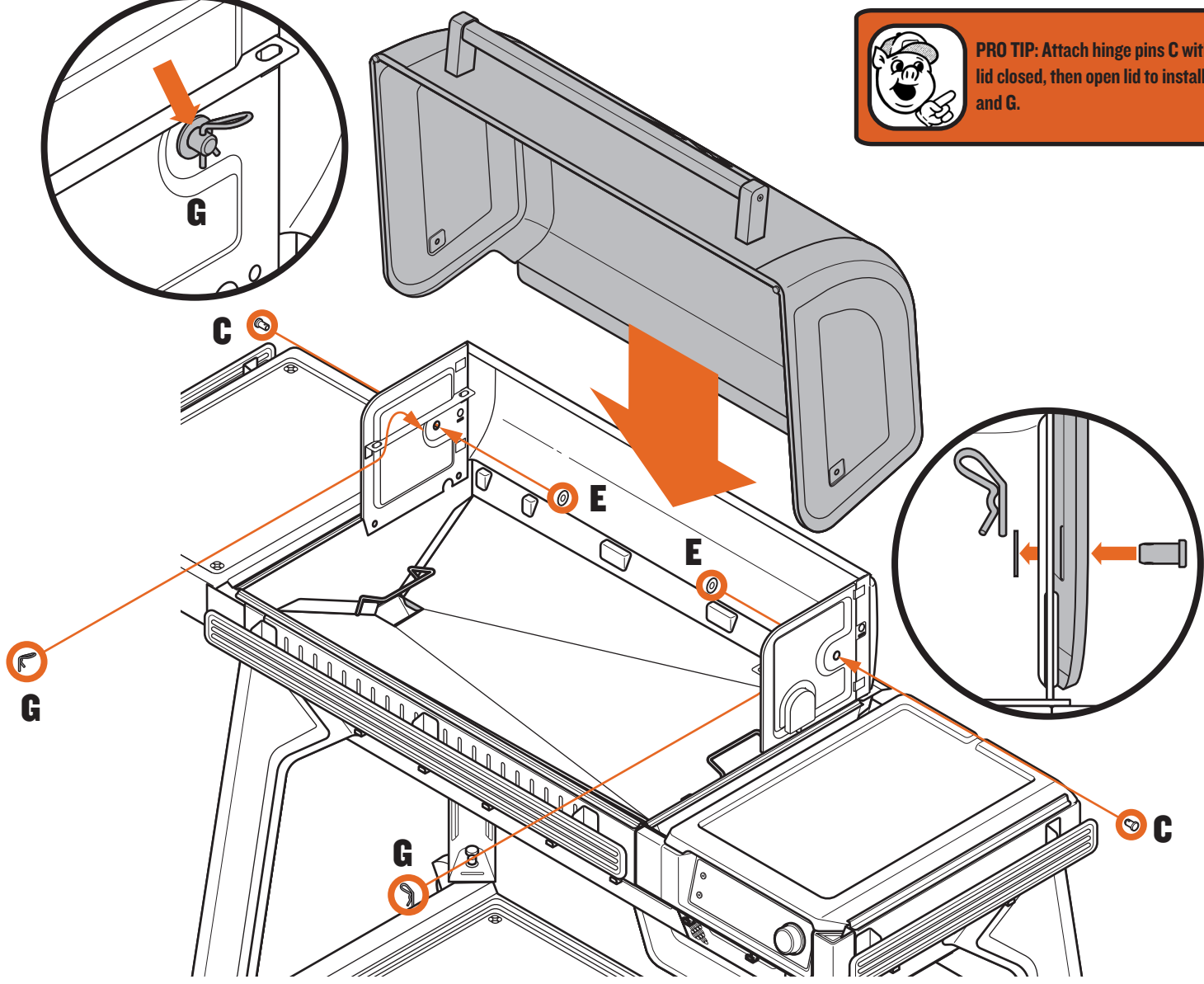



# 5 INSTALL GRATES

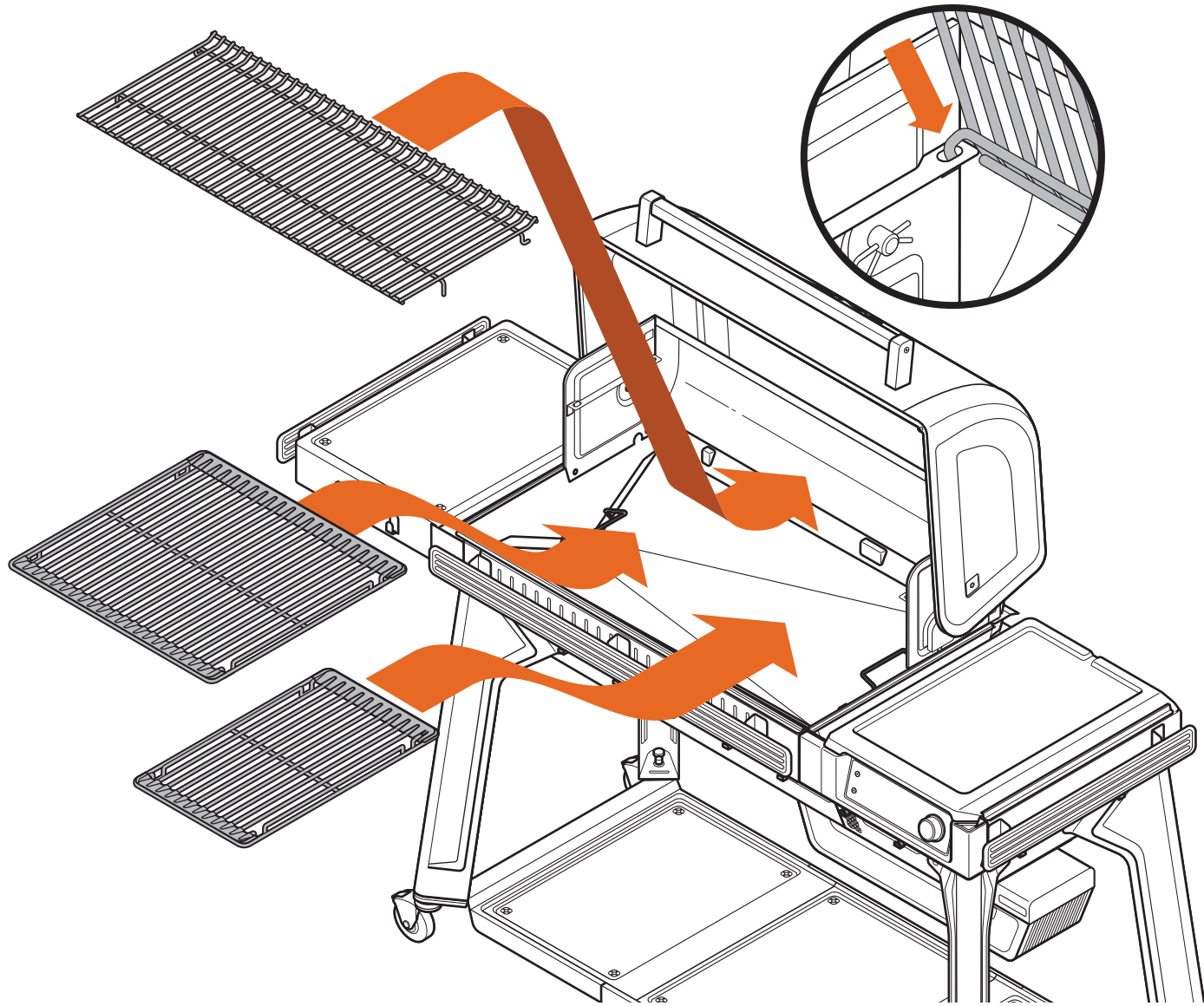
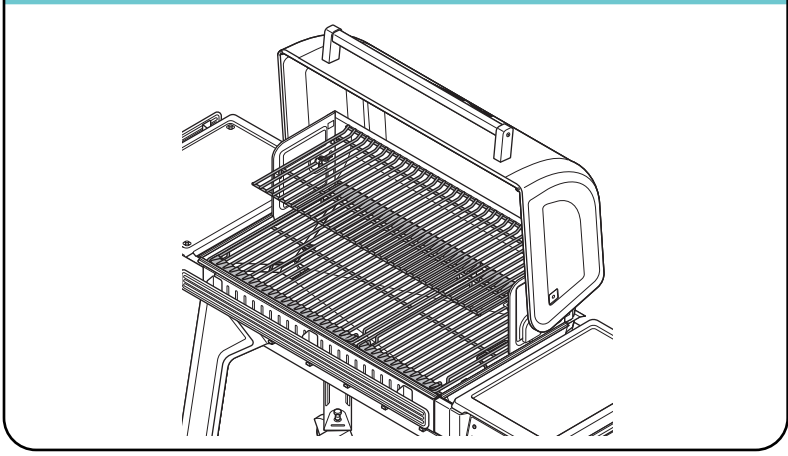



# 6 INSTALL GREASE & ASH KEG

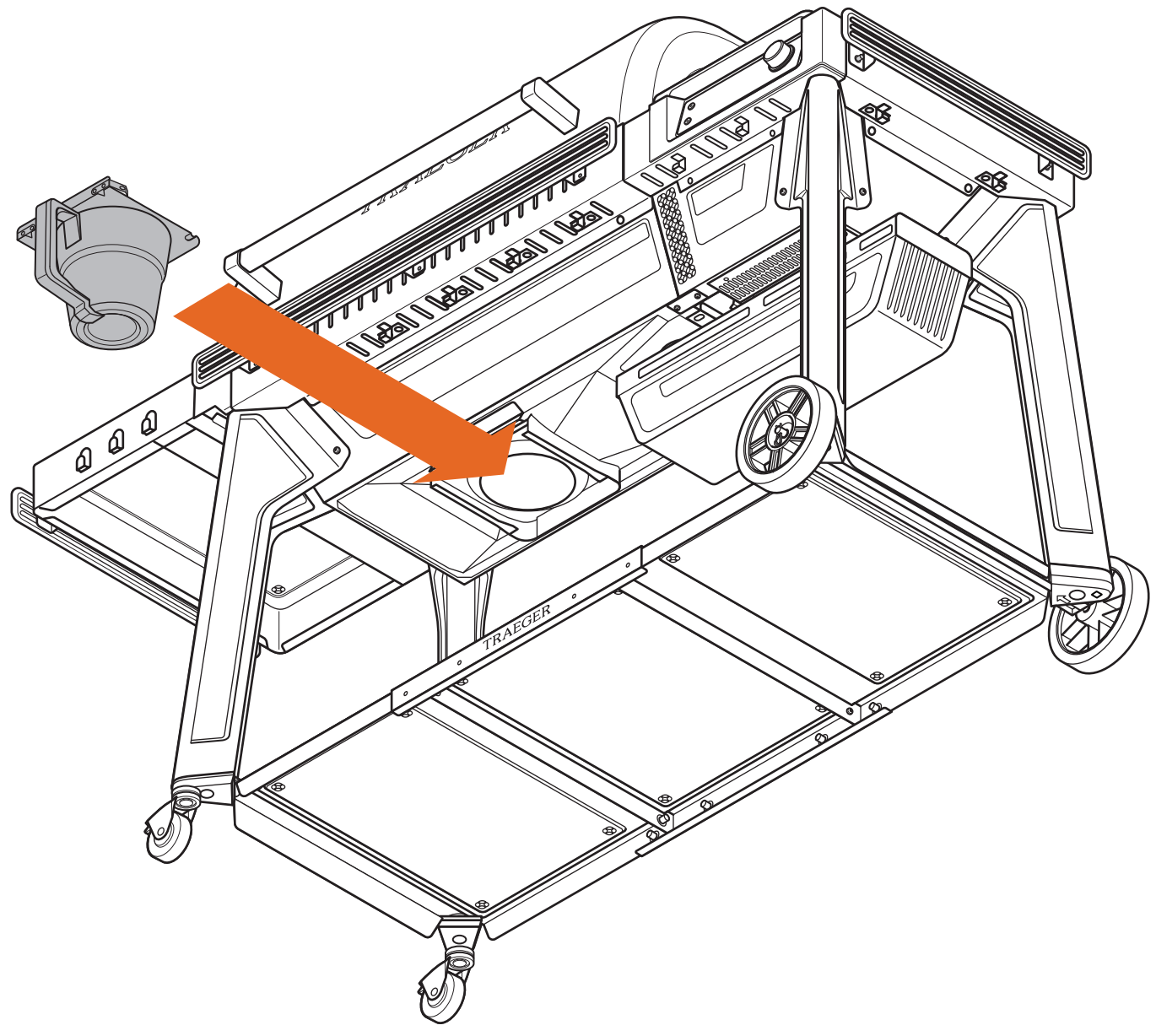
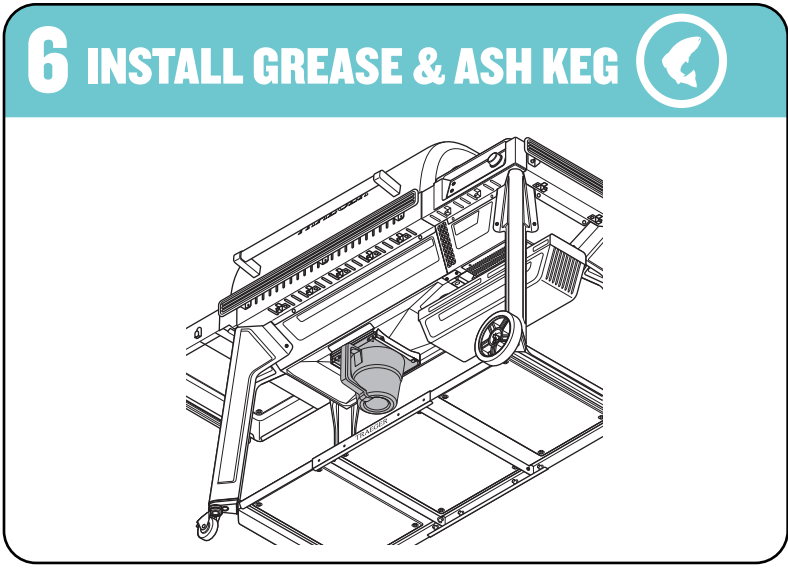



# 7 PLUG IN POWER CORD

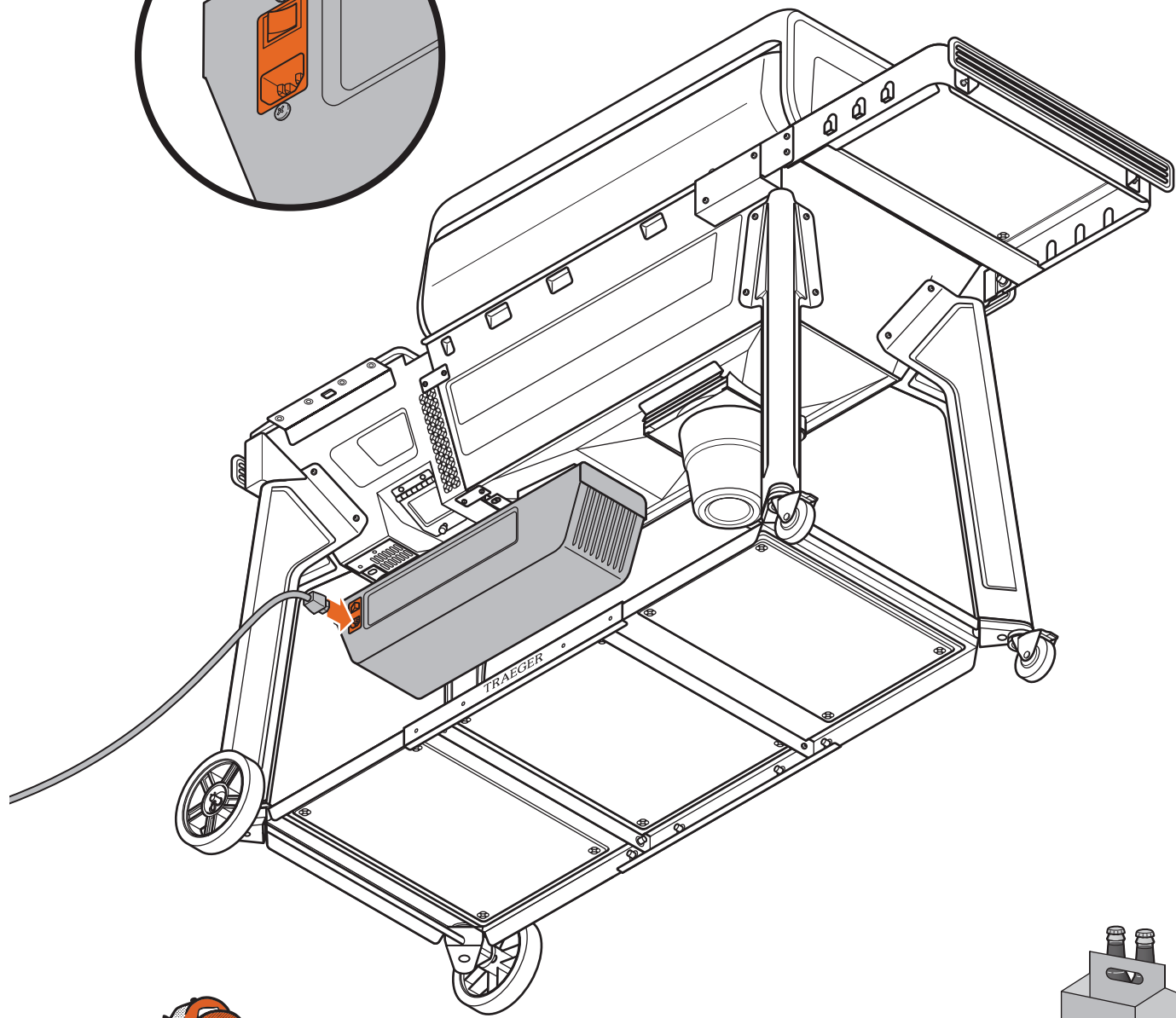
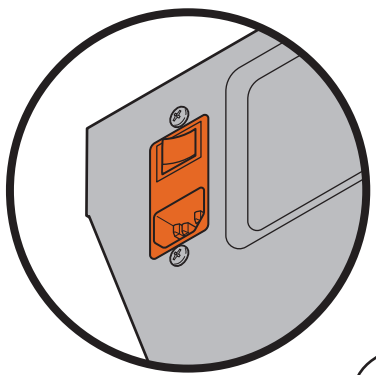
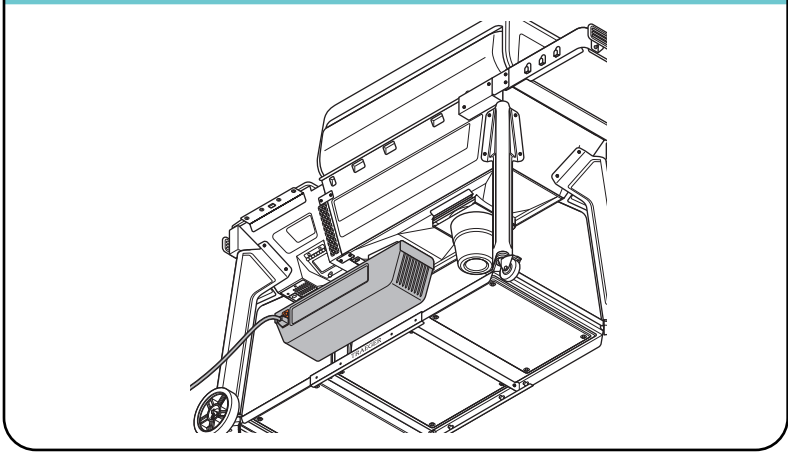

**NICE WORK!**  
**CHAPTER 4 COMPLETE!**

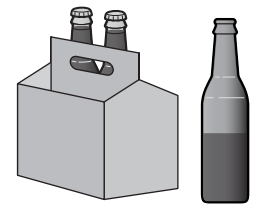

# STORING PARTS AND ACCESSORIES

## Wired Probe and Power Cord

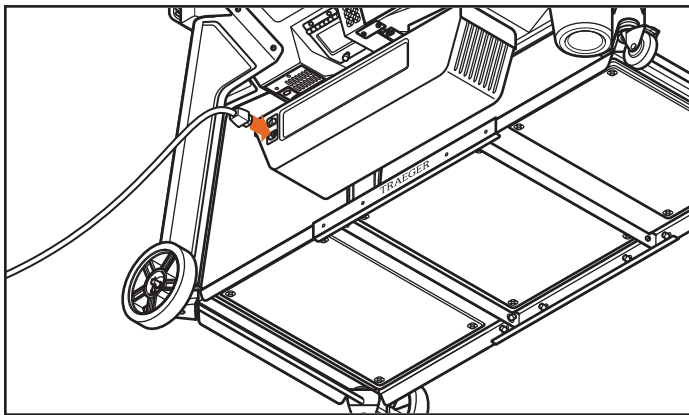
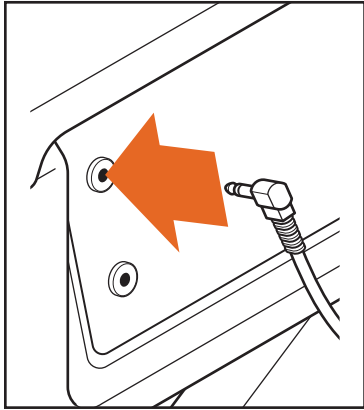

**TO STORE:**

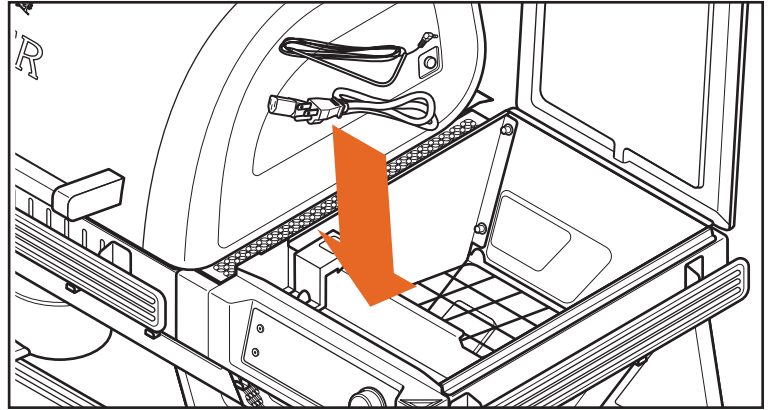

## Grill Grates, Drip Tray, Grease Chute, and Ember Shield

**TO STORE DURING CLEANING:**

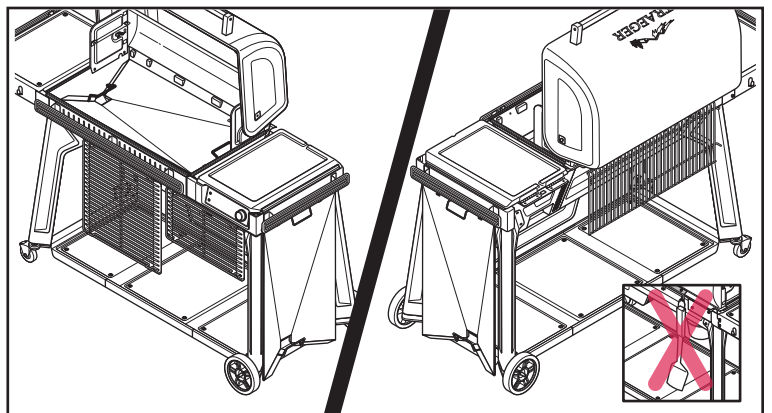
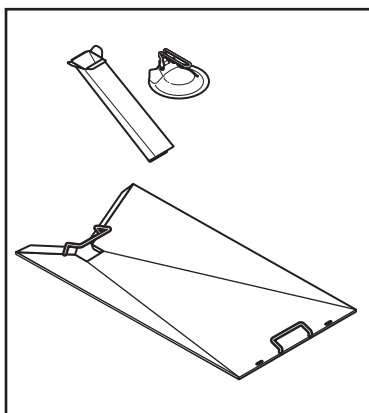
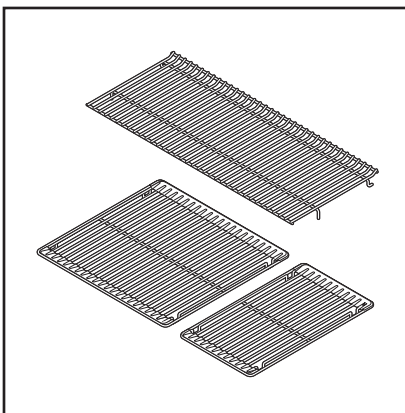

**PRO TIP:** Do not hang or store cooking utensils or power cord on grate hooks. Doing so could damage the utensils or power cord.

# CONNECTING YOUR GRILL

Our dedication to delivering world-class products and experiences means we are constantly working to improve grill performance and features. We highly recommend connecting your Traeger Woodridge Grill to WiFIRE by following the instructions below. When your grill is connected and on, updates will automatically download, ensuring your grill is always operating at peak performance.

## IMPORTANT:

- Make sure your smart device is running on the latest operating system and that Bluetooth is turned on.
- If using an Android device, turn on location services.
- To connect your grill to your home Wi-Fi, your grill must be powered on. Make sure the main power switch is pressed to ON (I) and lit up.
- Your home Wi-Fi router signal must be 2.4 GHz (a dual band router should also work). The 2.4 GHz band is currently industry standard for connected appliances. It has better range and penetrates walls/ceilings/obstacles better than 5 GHz, which your grill cannot pick up.

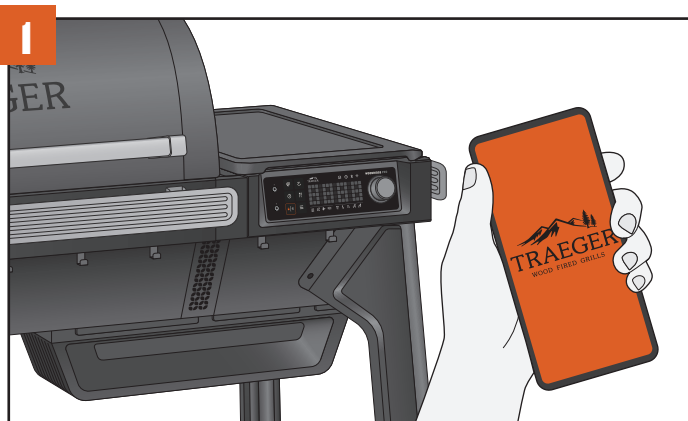
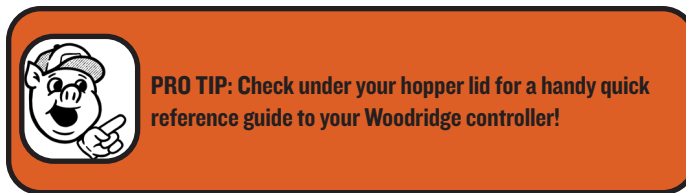
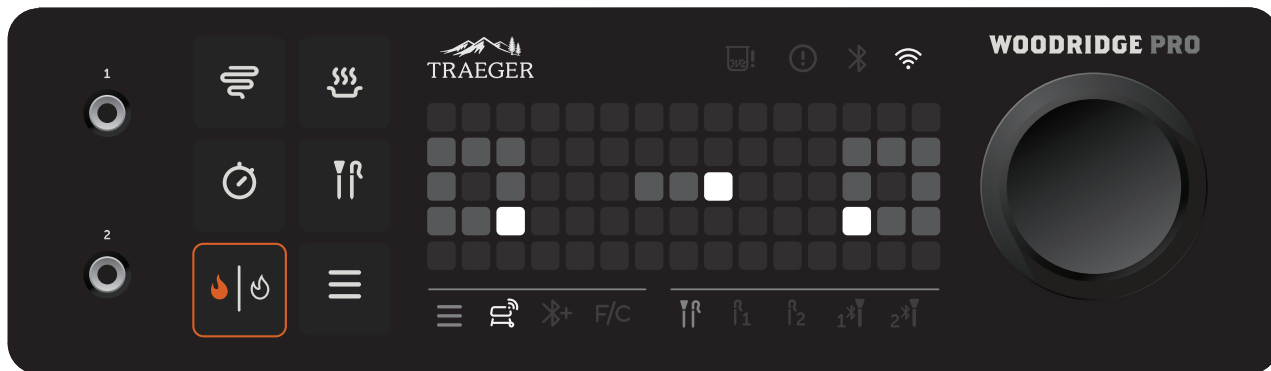

**1** Go to the Apple App Store or Android Google Play Store to download the latest version of the Traeger App.

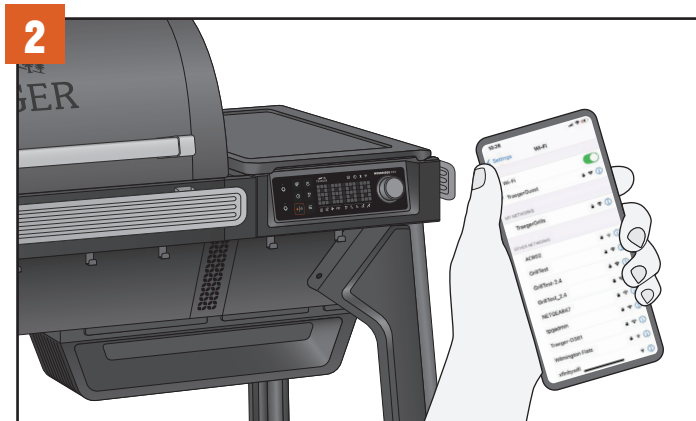

**2** Ensure your smart device is connected to the Wi-Fi network to which you want your grill connected. The router signal must be 2.4 GHz, as the grill is not compatible with 5 GHz.



After powering on your grill, tap the menu button. You will see the Wi-Fi grill icon light up in the menu bar below the dot matrix, and an animation of a Wi-Fi signal with a question mark will be displayed. Press the selection dial to select this option and begin the connection process.

**NOTE:** You can navigate menu options by turning the selection dial after tapping the menu button. As you turn the dial, the menu bar icons below the dot matrix display will light up to indicate your selection.



After selecting WiFIRE, the pairing animation above will display on screen, indicating that your grill is broadcasting its Bluetooth signal and is ready to pair. Open your smart device to the Traeger App and sign in to your account. On the home screen of the Traeger App, tap the grill icon in the lower centre of the screen to start connecting.

Follow the instructions on your Traeger App to (1) pair your smart device to your grill (via temporary Bluetooth connection), (2) connect your grill to your desired 2.4 GHz home Wi-Fi network, and (3) complete the grill setup process.

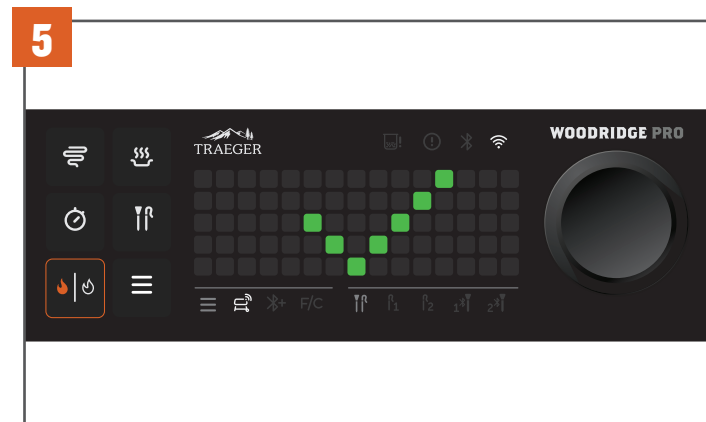

A green checkmark will display on your controller to indicate that you have successfully connected to WiFIRE. The Wi-Fi icon in the top right above the dot matrix display will stay lit up when the grill is connected.

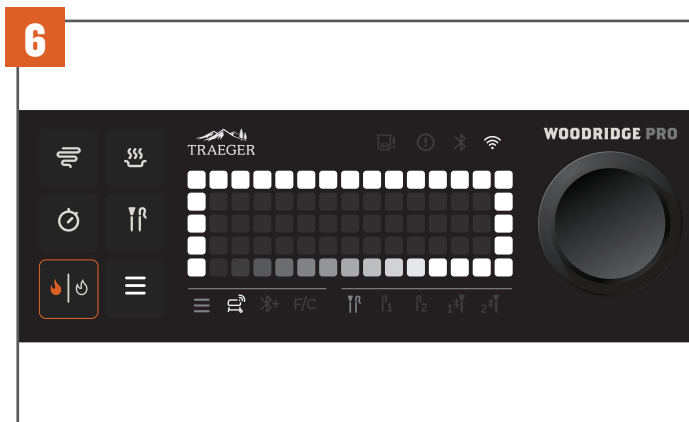

Once connected to WiFIRE, you might see this animation on your screen. Don't turn off your grill until you see a green checkmark. This means that your grill is downloading and applying an update. Just like your smartphone, these updates keep your grill running smoothly, securely, and at peak performance. Once the update is done, you'll see a green checkmark and the grill will return to the idle mode – let's cook!

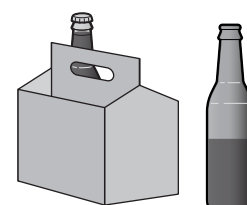

# SEASONING YOUR GRILL

 **PRO TIP:** Seasoning must be completed before cooking food on your grill. For more information, scan here to access the Seasoning Guide.

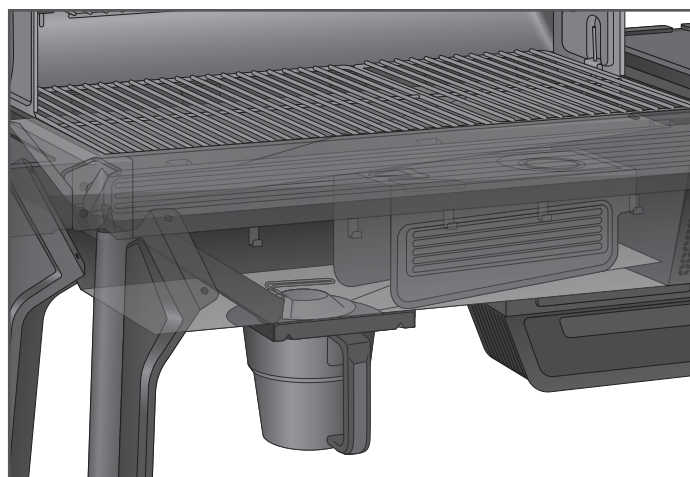

## IMPORTANT:

- Make sure all components are properly installed in the grill and that all packaging/shipping materials are removed prior to seasoning.
- Do not wipe protective grease coating off of components before seasoning. This coating provides a more durable burn-in protective layer.

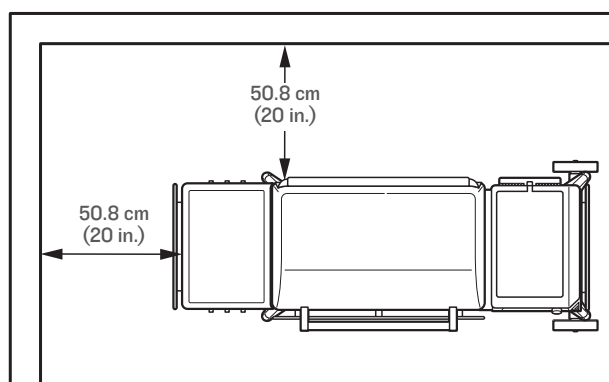

## ⚠️ WARNING Fire Hazard

- When operating your Traeger Grill, maintain a **MINIMUM** distance of 50.8 cm (20 inches) from the grill to any nearby combustibles, including wooden railings, home siding, window frames, furniture, trees, trash receptacles, etc.

Before you can cook on your grill, the grill must be seasoned. This is a hands-off process in which the empty grill gets heated to a very high temperature. This seasoning cycle ensures the grill is cleaned of any factory residue, primed, and ready for optimal performance.

## ⚠️ DANGER Carbon Monoxide Hazard

Burning wood pellets produces carbon monoxide which may lead to illness, serious injury, and/or death. Follow these guidelines to prevent this colorless, odorless gas from poisoning you, your family, your pets, or others:

- Only use your Traeger Grill outside in a well-ventilated area. This grill is intended for **OUTDOOR USE ONLY**.
- **Never** use your Traeger Grill in any enclosed area or any area without adequate ventilation.
- Know the symptoms of carbon monoxide poisoning: headache, dizziness, weakness, nausea, vomiting, sleepiness, and confusion. Carbon monoxide reduces the blood's ability to carry oxygen. Low blood oxygen levels can result in loss of consciousness and death.
- See a doctor if you or others develop cold- or flu-like symptoms while cooking or in the vicinity of this appliance. Carbon monoxide poisoning, which can easily be mistaken for a cold or flu, is often detected too late.
- Alcohol consumption and drug use increase the effects of carbon monoxide poisoning.
- Carbon monoxide is especially toxic to mother and child during pregnancy, infants, the elderly, smokers, and people with blood or circulatory system problems, such as anemia or heart disease.

## ⚠️ WARNING Fire Hazard

- **Never** use gasoline, lantern fuel, kerosene, lighter fluid, or other flammable materials to start or "freshen up" a fire.
- **Never** use or store flammable liquids or other combustible materials near the grill.

## ⚠️ WARNING Burn Hazard

Ashes should always be completely cool before handling. Ashes should be placed in a metal container with a tight-fitting lid. The closed container of ashes should be placed on a noncombustible floor or on the ground, well away from all combustible materials, pending final disposal. Ashes should be retained in the closed container until they are disposed of.

## ⚠️ WARNING Do Not Use Fuel Pellets

Never use heating fuel pellets in the grill because they may contain hazardous contaminants and additives and may damage the grill.

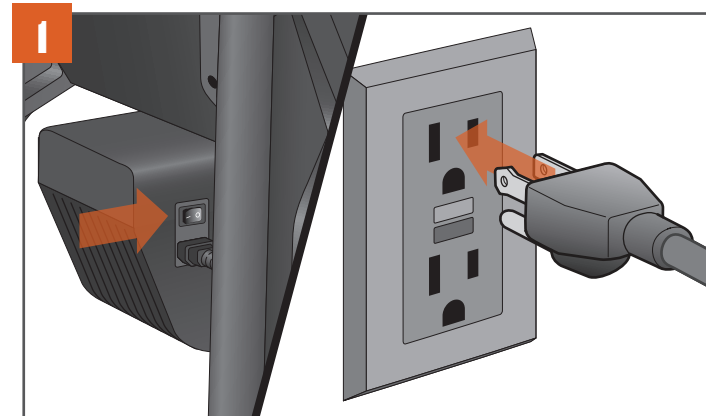

With the main power switch set to OFF (0), connect the power cord to your grill. Then plug the power cord into a properly grounded/earthed electrical outlet protected by a Ground Fault Circuit Interrupter (GFCI).

**NOTE:** Plug appearance may vary by region.



To add pellets, open the hopper lid and inspect for any foreign objects in the auger. Fill the hopper with pellets at least to the safety grate and close the lid.

**USE ONLY TRAEGER HARDWOOD PELLETS.** This product is developed and tuned using only Traeger pellets. Traeger pellets are crafted to meet strict quality and performance standards. Using pellets not manufactured by Traeger may result in inconsistent performance, poor flavour, and temperature inconsistency.



Turn the selection dial to set the grill's temperature to 350°F (177°C), then press the dial. Press the ignite/shutdown button.



**PRO TIP:** This seasoning process is important to ensure proper grill performance. Make sure that all internal components have been properly installed prior to this seasoning cycle and that there is no food on the grill grates during this cycle.

**WARNING! ELECTRICAL SHOCK HAZARD**  
HAZARDOUS VOLTAGE IS PRESENT, WHICH CAN SHOCK, BURN, OR CAUSE DEATH.

- GROUND FAULT CIRCUIT INTERRUPTER (GFCI) PROTECTION MUST BE PROVIDED ON THE CIRCUIT(S) OR OUTLET(S) TO BE USED FOR THE OPERATION OF THIS TRAEGER GRILL.

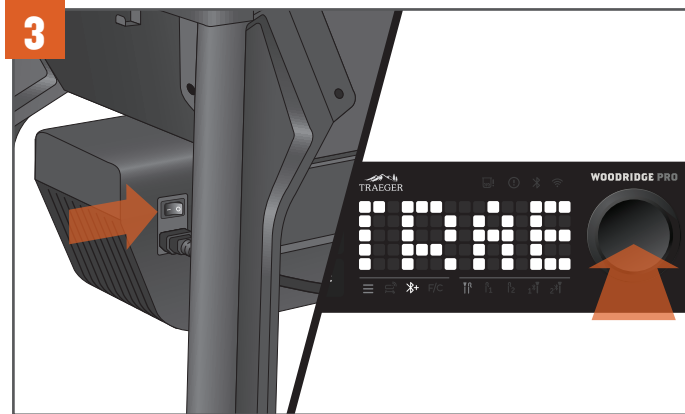

Press the main power switch, located on the back of the auger box, to ON (I). Press the selection dial to wake up the controller. "TRAEGER" will scroll across the screen, indicating the grill is on.

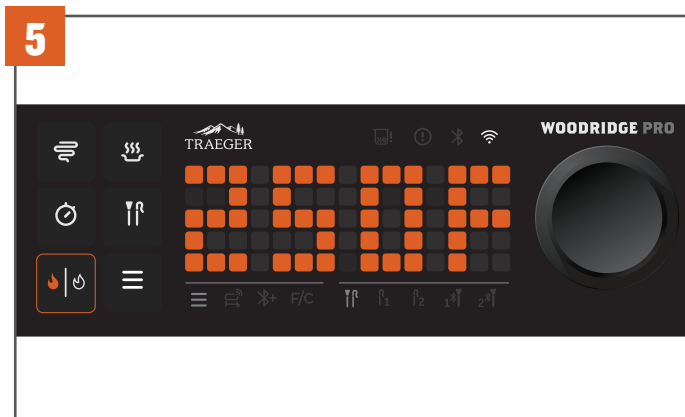

The grill temperature will display as it increases to the set temperature.

# SEASONING YOUR GRILL CONTINUED

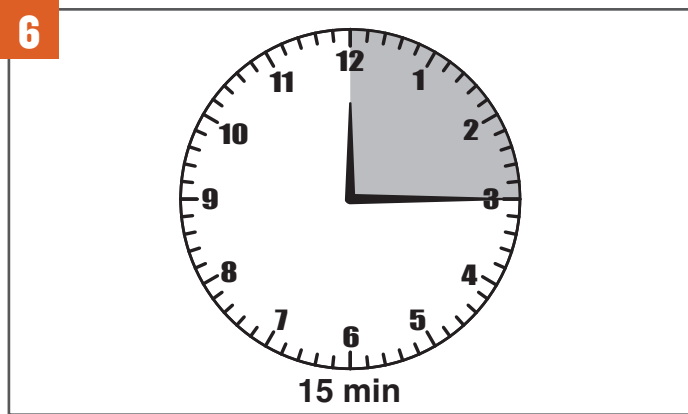

Once the grill has reached 350°F (177°C), let it run for 15 minutes. While the grill is seasoning, you may see dark or excessive smoke and ash; this is normal and will be less on future startups.

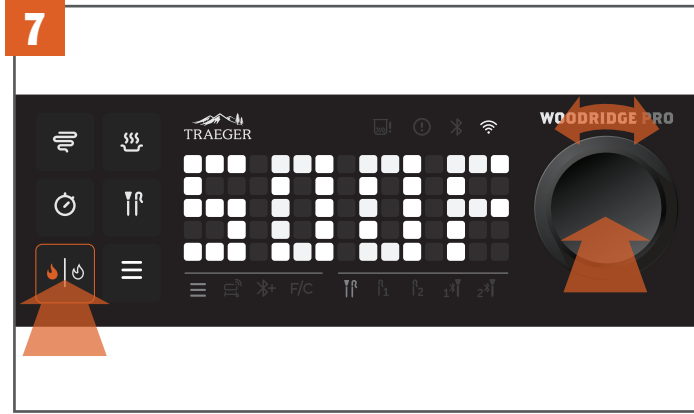

After 15 minutes at 350°F (177°C), increase the temperature to 500°F (260°C).

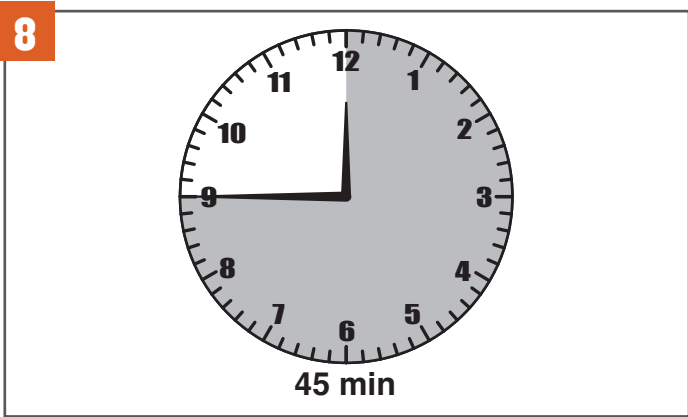

Once the grill has reached 500°F (260°C), let it run for another 45 minutes to ensure seasoning is completed properly.  
**NOTE:** Getting to first-time seasoning temperature may take up to an hour.

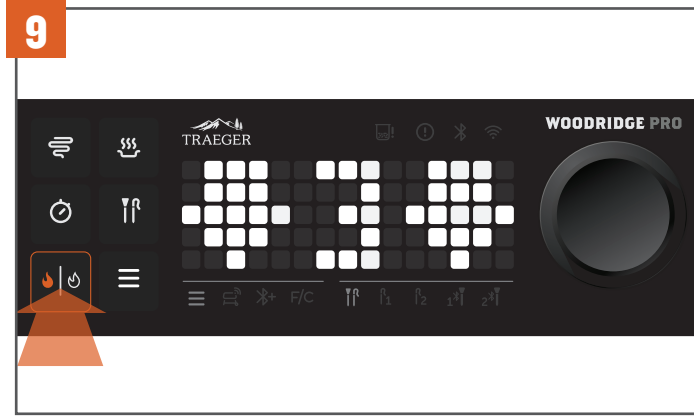

After 45 minutes at 500°F (260°C), shut down the grill and let the shutdown cycle complete. To shut down your grill, press and hold the ignite/shutdown button or the selection dial for three seconds until the display shows the shutdown animation.

**NOTE:** Always initiate a shutdown cycle after each and every cook.

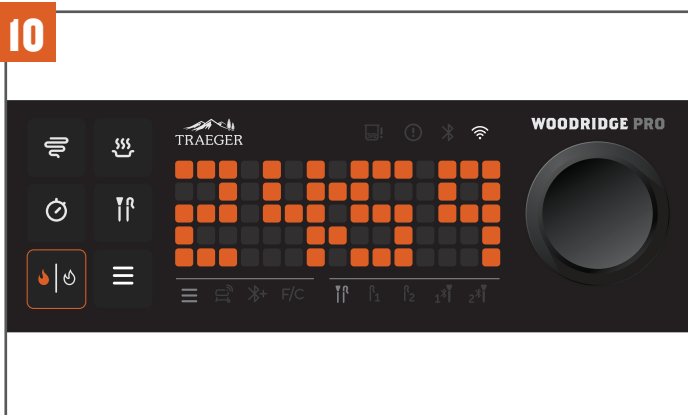

A countdown timer begins while the grill is shutting down. You will hear the fan continue to run.

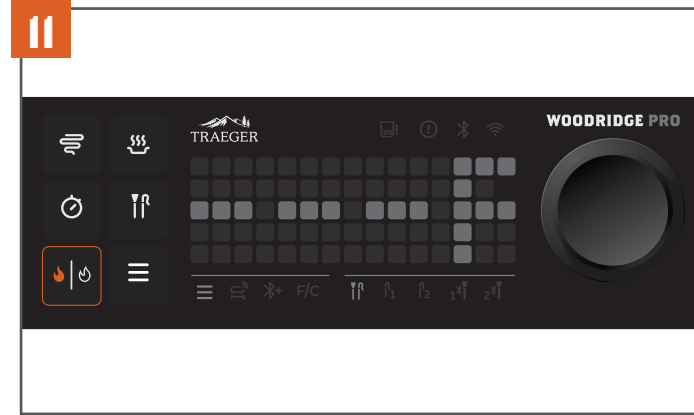

Once this countdown is complete, the shutdown cycle is complete.  
**NOTE:** It is normal to observe ash on the drip tray and/or grill grates after seasoning. Simply wipe away ash on grill grates prior to your first cook.

