

KASUTUS- JUHEND

WOODRIDGE

TERE TULEMAST PUUKÜTTEGA REVOLUTSIOONI

Soovime, et saaksite oma Traegerist maksimumi.

OLULINE TEADE / IMPORTANT NOTICE

See tõlge on antud üksnes teenusena. Tootega kaasasolev ingliskeelne kasutusjuhend on õiguslikult siduv dokument. Lahknevuste korral on ülimuslik ingliskeelne versioon.

This translation is provided as a courtesy service only. The original English manual included with the product is the legally binding document. In case of any discrepancy, the English version shall prevail.

ÕIGUSLIK TEADE JA TÕLGE

See dokument on eestikeelne tõlge, mille pakub Traeger Pellet Grills Europe ApS üksnes teenusena, et muuta kasutusjuhend kättesaadavamaks eestikeelsetele kasutajatele.

Tootega füüsiliselt kaasas olev ingliskeelne originaaljuhend on ainus õiguslikult siduv dokument. Selle tõlke ja originaaldokumendi vahelise lahknevuse korral kehtib alati ingliskeelne versioon.

See tõlge ei asenda originaaljuhendit. Enne Traeger Woodridge'i grilli paigaldamist, kokkupanemist või kasutamist lugege originaalne ingliskeelne juhend täies ulatuses läbi.

Pildid, tehnilised skeemid ja graafilised viited ei ole originaaldokumendiga võrreldes muutunud; illustatsioonidesse integreeritud tekstid jäävad inglise keeles.

Tehnilise abi, garantii või klienditeeninduse osas vaadake kontaktteavet selle dokumendi lõpus või külastage support.traeger.com.

ENGLISH NOTICE

This document is an Estonian translation provided by Traeger Pellet Grills Europe ApS solely as a courtesy service. The original English manual is the only legally binding document.

OLULISED OHUTUSNÕUDED

LUGEGE KÕIK JUHISED ENNE OMA TRAEGER-GRILLI PAIGALDAMIST JA KASUTAMIST

OHUTUSHOIAATUSTE VÕTI

OHT

Tähistab vahetut ohtlikku olukorda, mis — kui seda ei väldita — põhjustab surma või tõsise vigastuse.

HOIATUS

Tähistab tõsise kehavigastuse või surma võimalust, kui juhiseid ei järgita.

ETTEVAATUST

Tähistab potentsiaalselt ohtlikku olukorda, mis — kui seda ei väldita — võib põhjustada väiksema või keskmise vigastuse.

OLULINE TULEKAHJUDE PÕHJUS ON NÕUTAVATE VAHEMAADE (ÕHURUUMIDE) MITTEHOIDMINE SÜTTIVATE MATERJALIDE JA GRILLI VAHEL. ON ÄÄRMISELT OLULINE, ET TOODE PAIGALDATAKS AINULT VASTAVALT NENDELE JUHISTELE.

Õigesti kasutatuna ja hooldatuna pakub puuküttega Traeger-grill teile, perele ja sõpradele aastaid rõõmu. Uus Traeger-grill on spetsiaalselt loodud, et muuta toiduvalmistamine lihtsamaks ja pakkuda optimaalset jõudlust ning maitsvaimat toitu.

Lugege see juhend täielikult läbi enne paigaldamist ja kasutamist. Kõik, kes seda grilli kasutavad, peavad samuti enne kasutamist lugema kogu juhendit. Juhiste eiramine võib põhjustada varalist kahju, kehavigastusi või surma. Pöörduge kohalike ehitus- või tuleohutusametite poole piirangute ja paigalduskontrolli nõuete osas. Hoidke need juhised alles.

OHT — Vingugaasi oht

Puidugraanulite põletamine tekitab vingugaasi (CO), mis võib põhjustada haigust, tõsist vigastust ja/või surma. Järgige neid juhiseid, et vältida selle värvitu ja lõhnatu gaasi mürgistust:

- Kasutage Traeger-grilli ainult väljas hästi õhutatud alal. Grill on mõeldud AINULT VÄLISKASUTUSEKS.
- Ärge kunagi kasutage Traeger-grilli suletud ruumis või ruumis ilma piisava ventilatsioonita.
- Tundke vingugaasi mürgistuse sümptomeid: peavalu, peapööritus, nõrkus, iiveldus, oksendamine, unisus ja segasus. Vingugaas vähendab vere hapnikutranspordivõimet.
- Pöörduge arsti poole, kui teil või teistel tekivad külmetuse või gripi taolised sümptomid toiduvalmistamise ajal või seadme läheduses.
- Alkoholi ja narkootikumide tarbimine suurendab vingugaasi mürgistuse mõju.
- Vingugaas on eriti mürgine emale ja lapsele raseduse ajal, imikutele, eakatele, suitsetajatele ning vere- või vereringeprobleemidega inimestele.

HOIATUS — Tuleoht

- Traeger-grilli kasutamisel hoidke MINIMAALSELT 50,8 cm (20 tolli) vahemaad grillist süttivate materjalideni, sealhulgas puidust käsipuud, hoonete vooderdused, aknaraamid, mööbel, puud, prügikastid jne.

- Ärge paigaldage ega kasutage seda grilli siseruumides ega põleva lae või väljaulatuva katuse all.
- Ärge paigaldage ega kasutage Traeger-grilli süttivatel põrandatel või pindadel.
- Ärge pange grillkatet ega midagi süttivat grilli all olevasse hoiualasse.
- Tulekahjuriski vähendamiseks eemaldage potid ja pannid seadmest, kui see töötab järelevalveta.

HOIATUS — Elektrilöögi oht

Esinevad ohtlikud pinged, mis võivad põhjustada elektrilöögi, põletuse või surma.

- Sellele Traeger-grillile kasutatavatele ahelatele või pistikupesadele tuleb paigaldada rikkevoolukaitse (GFCI).
- Eemaldage toitejuhe enne hooldust, kui selles juhendis pole teisiti märgitud.
- Pikenduskaabli kasutamisel kasutage ainult väliskasutuseks sobivat kaablit, et vältida elektrilööki.
- Kasutage pikendusjuhet No. 18 AWG.
- Ärge muutke Traeger-grilli pistikut ega pikenduskaabli pistikut mingil moel.
- Veenduge enne iga kasutuskorda, et pikendusjuhe oleks heas seisukorras.
- Ärge ühendage pikendusjuhtmeid omavahel.
- Hoidke pikendusjuhe lume ja seisva vee eest.

HOIDKE NEED JUHISED ALLES

SISUKORD

Olulised ohutusnõuded	2
Maitse loeb	8
Tutvuge oma grilliga	10
Kiirviite juhend	13
Esimesed sammud	14
Onboarding – Osa 1: Ühenda grill	14
Onboarding – Osa 2: Grilli sisseelamine	16
Igapäevane Traegerimine	19
Grilli väljalülitamine	22
Grilli lisafunktsioonide kasutamine	23
Pelletimahuti tühjendamine	33
Grilli hooldus	34
Veaotsing	36
Kasutusnõuanded	37
Teenindus	37
Garantii	38

TUTVUGE OMA GRILLIGA

Grillimispind: 0.56 m² (860 in²)

Pelletimahuti: 11 kg (24 lb)

TRAEGER-GRILLI GARANTII

PIIRATUD 10-AASTANE GARANTII

Traeger Pellet Grills Europe ApS, Kattedgatvej 40, 2150 Kopenhagen, Taani, („Traeger“) garanteerib selle Traeger-grilli alltoodud tabelis loetletud komponendid, katte ja garantiiajad normaalse kasutuse ja korraliku hoolduse korral. See garantii antakse lisaks teie kui ostja õigustele teie elukohariigi seaduste järgi ega võta teilt nende seaduste pakutavat kaitset. Vastav garantiiaeg algab originaalse ostulepingu sõlmimise kuupäevast Traegeri volitatud edasimüüjaga ja antakse Euroopas asuvatele klientidele.

Komponent	Aeg	Kate
Korpus, jalad ja pelletimahuti kaas	10 aastat	Ei roosteta läbi
Kontroller, teo mootor, tigu ja ventilaator	3 aastat	Materjali- ja tootmisvead
Tilkumisalus, sädemekaitse ja soojusplaat	3 aastat	Materjali- ja tootmisvead
Emailitud grillrestid	3 aastat	Ei roosteta läbi
Hõõgvarras, juhe, RTD ja termopaar	1 aasta	Materjali- ja tootmisvead
Lihatermomeetrid ja juhtmevabad lihatermomeetrid	1 aasta	Ei roosteta läbi

Seda garantiid reguleeritakse Taani õigusega. See õiguse valik ei võta teilt teie elukohariigi seaduste pakutavat kaitset.

Traegeri kogu vastutus ja teie ainus hüvitis on teie Traeger-grilli vigaste osade asendamine. Traegeri klienditeeninduse poolt tagastamiseks heaks kiidetud originaalsed osad tuleb tagastada ettemakstud saatekuluga. Traeger võib asendada vigased osad uute või renoveeritud osadega oma äranägemise järgi.

See garantii on tühine, kui: (i) grilli ei kokku panda ega kasutata vastavalt Traegeri kasutusjuhiste; (ii) grilli ei osteta volitatud edasimüüjalt; (iii) grill müüakse edasi; (iv) on kasutatud muid kütuseid kui pelletigrillidele mõeldud puidugraanulid; (v) on kasutatud küttepellette; (vi) grilli on kasutatud ärilises kasutuses; (vii) kasutaja on lubanud kahju, kuritarvitamist või on jätnud grilli hooldamata; või (viii) grilli on lubamatult muudetud.

Garantiinõude menetlemiseks võtke ühendust Traegeri klienditeenindusega ülaltoodud telefoninumbri või aadressil. Traeger nõuab tõendit teie ostukuupäeva kohta volitatud edasimüüjalt.

TEENINDUS

TRAEGERI LEGENDAARNE KLIENDITEENINDUS on parim, mis on olemas. Kui teil on küsimusi Traeger-grilli kohta või vajate nõuandeid, on meie kogenud eksperdid teie käsutuses 365 päeva aastas.

Telefon (rahvusvaheline): traeger.com/support/international-contact-info

Veebisait: support.traeger.com

Adress: Traeger Pellet Grills Europe ApS — Kattegatvej 40, 2150
Kopenhaagen, Taani

GETTING TO KNOW YOUR GRILL

Refer to the Assembly Guide to assemble your Traeger Woodridge Grill.

PARTS AND FEATURES



PART	DESCRIPTION	PART	DESCRIPTION
1	UPPER GRILL GRATE	10	P.A.L. POP-AND-LOCK ACCESSORY RAILS
2	LOWER GRILL GRATE	11	LEGS
3	MODIFIRE GRILL GRATE	12	HOOVES
4	DRIP TRAY	13	LID HANDLE
5	HEAT BAFFLE	14	LID
6	EMBER SHIELD	15	WiFi CONTROLLER
7	GREASE DRAIN CHUTE	16	AUGER BOX
8	EZ-CLEAN GREASE & ASH KEG	17	ALL-TERRAIN WHEELS
9	WIRED MEAT PROBE	18	BRACE

WEIGHT CAPACITY

Pellet Hopper: 11 kg (24 Pounds)



PELLET HOPPER

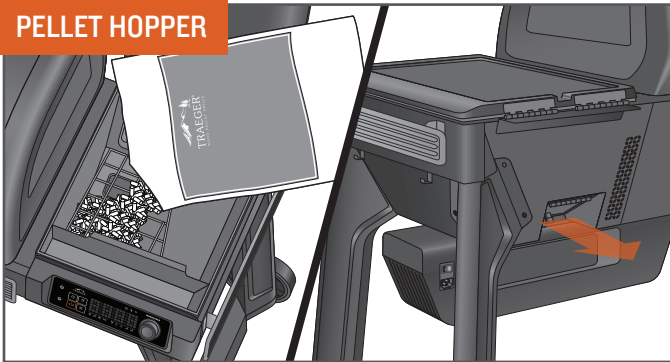

The hopper's 11 kg (24 lb) capacity allows for hours of cooking with no need to refill. Pellets can be emptied through the pellet release door on the back by unscrewing the knob.

USE ONLY TRAEGER HARDWOOD PELLETS. This product is developed and tuned using only Traeger pellets. Traeger pellets are crafted to meet strict quality and performance standards. Using pellets not manufactured by Traeger may result in inconsistent performance, poor flavour, and temperature inconsistency.

GRILLING SPACE

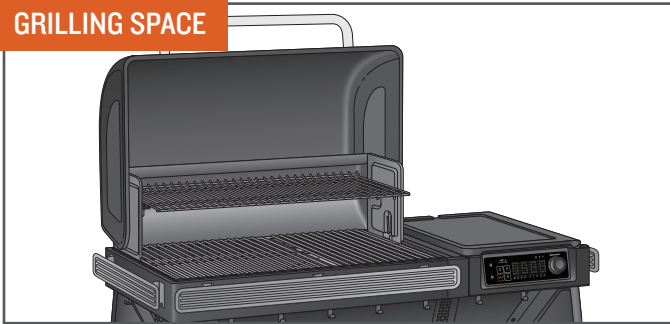

With 0.56 m² (860 in.²) of grilling space, your Traeger Woodridge Grill has the real estate for party-sized orders of T-bones or racks of ribs, with enough room left over to handle those side dishes, too.

VERSATILITY

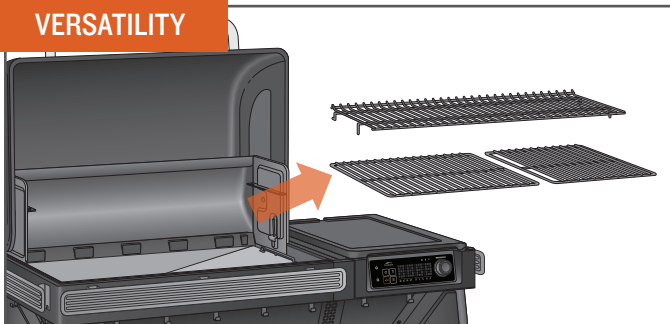

A removable upper grill grate and the lower ModIFIRE grill grate offer you the versatility you need to cook anything.



PRO TIP: The upper grate can be stored on back of the grill when cooking large items like turkeys (see page 34 for more information).

GRILL SHAPE

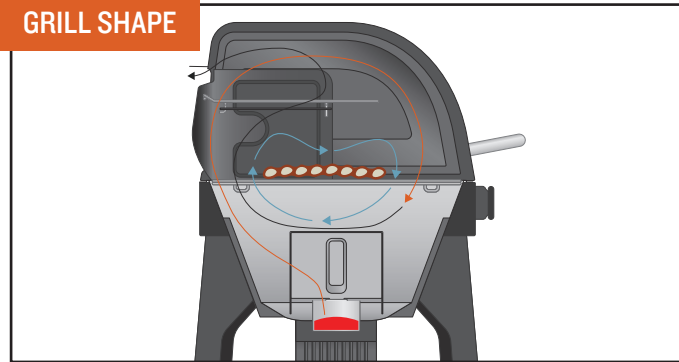

Your Traeger Woodridge Grill has a unique barrel shape that helps funnel the smoke in and around your food for better, more flavourful results.

WIFIRE CONNECTIVITY



Download the Traeger App and connect your grill to unlock the power of Traeger's WiFIRE Technology. With the Traeger App you can remotely control your grill from anywhere, and your grill will also receive the latest and greatest firmware updates, keeping your grill operating at peak performance. Once connected, the Traeger App also lets you enable the Keep Warm Mode. See "Onboarding Part I: Connecting Your Grill" (page 14) for instructions on how to connect your grill to your phone.

NO FLARE-UPS

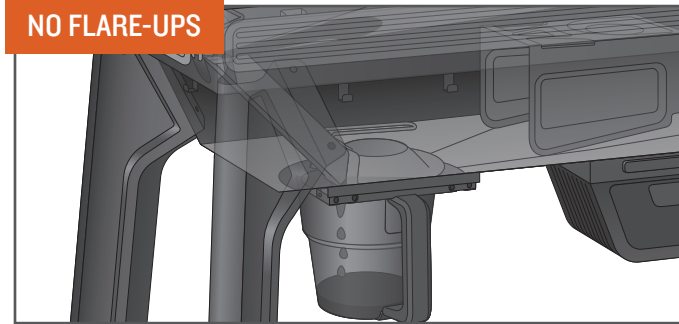

All grease is safely channelled into the EZ-Clean Grease & Ash Keg for disposal. This, combined with regular maintenance, prevents flare-ups and nasty fireballs from destroying your food.



PRO TIP: Keep your grill clean. See "Operating Tips" (page 37) and "Maintaining Your Grill" (page 34).



GETTING TO KNOW YOUR GRILL CONTINUED

YOUR WIFIRE DIGITAL CONTROLLER Your Traeger Woodridge Grill is equipped with a state-of-the-art Traeger Controller with WiFIRE technology that is Wi-Fi-capable and Bluetooth-enabled. Before you begin using the grill, familiarise yourself with the different features of the controller. Once the main power switch (located on the back side of the auger box) is ON (I), tap the ignite/shutdown button or turn the selection dial to wake the controller from sleep.

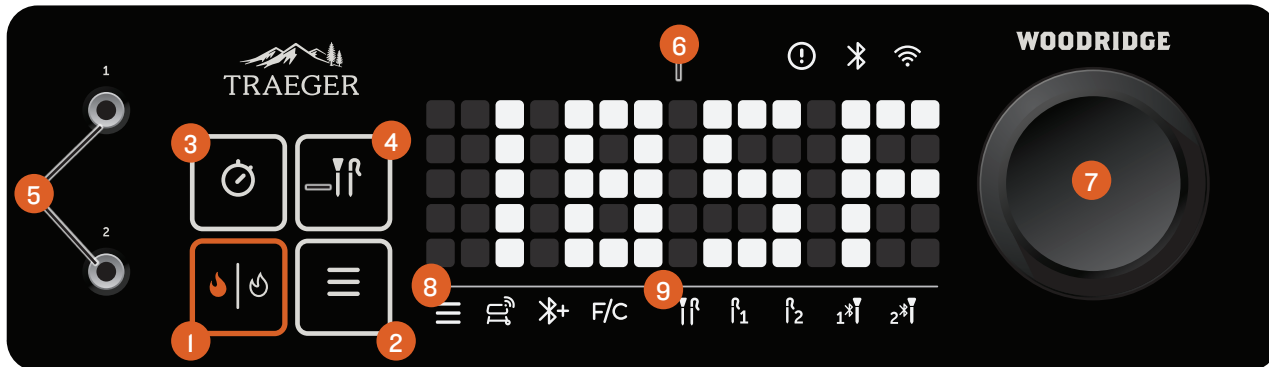

PRO TIP: On a good weather day, it is completely normal for a Traeger Grill to experience temperature fluctuations of +/- 25°F. These fluctuations are actually a key component in creating the smoke flavour we at Traeger love. Your Traeger Grill is designed to manage these fluctuations on its own. No need to change the set temperature! Any significant fluctuation could be the result of wind, air temperature, improper use, lack of grill maintenance, or opening the lid too often.

1 IGNITE/SHUTDOWN

Use this button to ignite your grill. If your grill is already running, press and hold this button to initiate a shutdown cycle.

2 MENU

You can connect your grill to WiFIRE, connect your Traeger wireless probe, and change temperature units from this menu.

3 TIMER

The timer is for your convenience only; it does not affect grill operation. For example, if you need to braise your meat for 15 minutes, set the timer for 15 minutes. A tone will sound when the time is up.

4 PROBES

After connecting any wired probes via probe jacks or any Traeger wireless probes via the menu button, tap this button to interact with the connected probes. After tapping this probe button, use the selection dial to toggle between connected probes. When your desired probe lights up in the probe menu bar, press the dial to set/modify a probe goal alert for when a probe has reached the desired internal temperature.

5 WIRED MEAT PROBE JACKS

Use these jacks to plug in wired temperature probes.

6 STATUS DISPLAY

This dot matrix display shows current grill temperature, status of cook cycle, and all things related to grill control and function.

7 SELECTION DIAL

Rotate this dial to move up and down through the displayed menu. Press the center of the dial to make a selection.

8 MENU BAR



The menu bar icons light up when you tap the menu button to indicate which setting you are editing. Turn the selection dial to cycle through these selections.



Grill Connectivity Icon: Lights up when you are adjusting the WiFIRE setting on your grill.



Add Bluetooth Accessory Icon: Lights up when you are pairing Bluetooth accessories.



F/C Icon: Lights up when you are adjusting your grill's temperature units to Fahrenheit or Celsius.

9 PROBE MENU BAR



The probe menu bar icons will light up as wired or Traeger wireless probes are connected, disconnected, selected, and activated for goal alerts. You can connect two wired probes and two Traeger wireless probes. Tap the probe button (upper right button to the left of the status display) to highlight connected probes in this probe menu one at a time. Use the selection dial to toggle between probes and press the dial to set/modify a probe goal alert for an individual probe. See the key below for probe states:

Off: Indicates that this wired or Traeger wireless probe is not connected.

Dim: Indicates that this wired or Traeger wireless probe is connected but not actively selected.

On: Icons will light up to full brightness when you tap the probe button. After tapping the button, turn the selection dial to see the selected probe icon turn to full brightness.

Blue: A probe icon will turn blue when a probe goal alarm has been set.

Blue + flashing: A probe icon will flash blue when a probe goal has been reached.

ONBOARDING PART 2: SEASONING YOUR GRILL



PRO TIP: Seasoning must be completed before cooking food on your grill. For more information, scan here to access the Seasoning Guide.



Before you can cook on your grill, the grill must be seasoned. This is a hands-off process in which the empty grill gets heated to a very high temperature. This seasoning cycle ensures the grill is cleaned of any factory residue, primed, and ready for optimal performance.

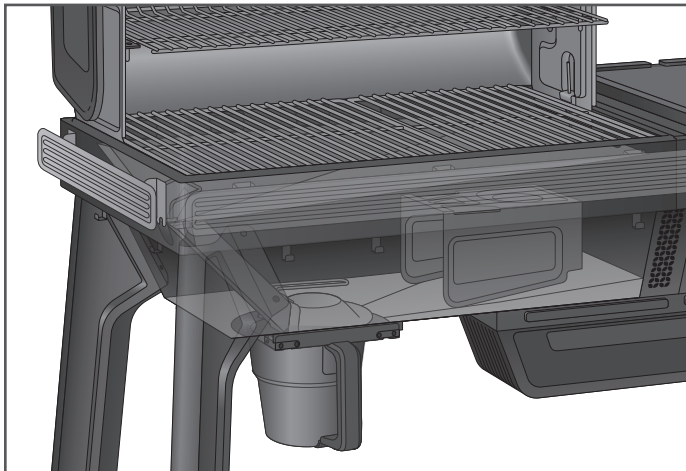

IMPORTANT:

- Make sure all components are properly installed in the grill and that all packaging/shipping materials are removed prior to seasoning.
- Do not wipe protective grease coating off of components before seasoning. This coating provides a more durable burn-in protective layer.

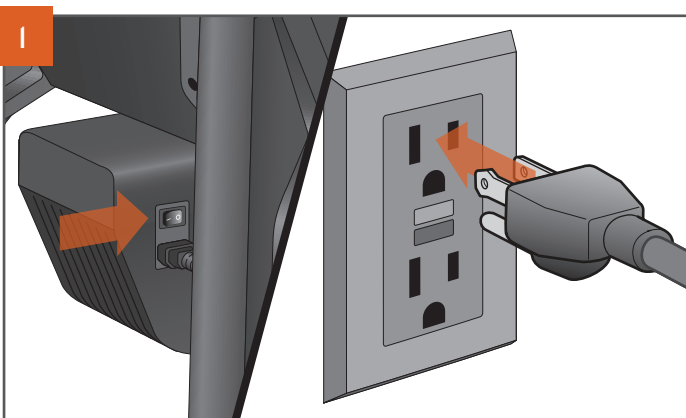

With the main power switch set to OFF (0), connect the power cord to your grill. Then plug the power cord into a properly grounded/earthed electrical outlet protected by a Ground Fault Circuit Interrupter (GFCI).

NOTE: Plug appearance may vary by region.



WARNING! ELECTRICAL SHOCK HAZARD
HAZARDOUS VOLTAGE IS PRESENT, WHICH CAN SHOCK, BURN, OR CAUSE DEATH.

- GROUND FAULT CIRCUIT INTERRUPTER (GFCI) PROTECTION MUST BE PROVIDED ON THE CIRCUIT(S) OR OUTLET(S) TO BE USED FOR THE OPERATION OF THIS TRAEGER GRILL.

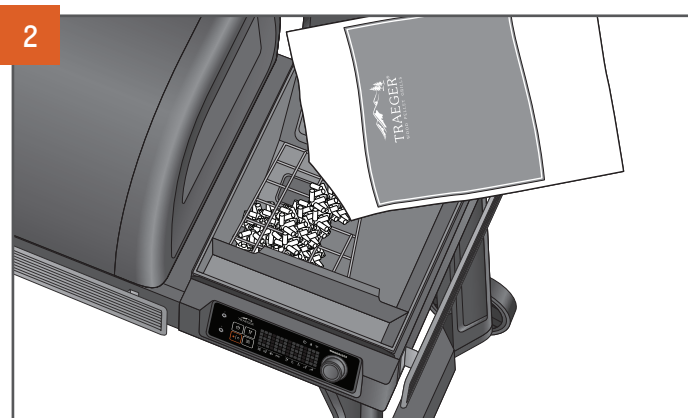

To add pellets, open the hopper lid and inspect for any foreign objects in the auger. Fill the hopper with pellets at least to the safety grate and close the lid.

USE ONLY TRAEGER HARDWOOD PELLETS. This product is developed and tuned using only Traeger pellets. Traeger pellets are crafted to meet strict quality and performance standards. Using pellets not manufactured by Traeger may result in inconsistent performance, poor flavour, and temperature inconsistency.

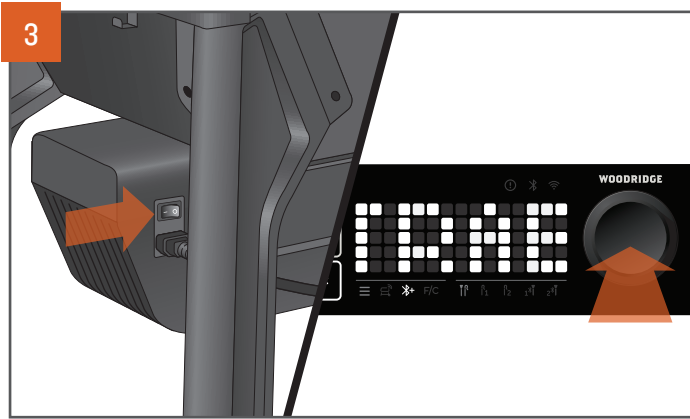

Press the main power switch, located on the back of the auger box, to ON (I). Press the selection dial to wake up the controller. "TRAEGER" will scroll across the screen, indicating the grill is on.

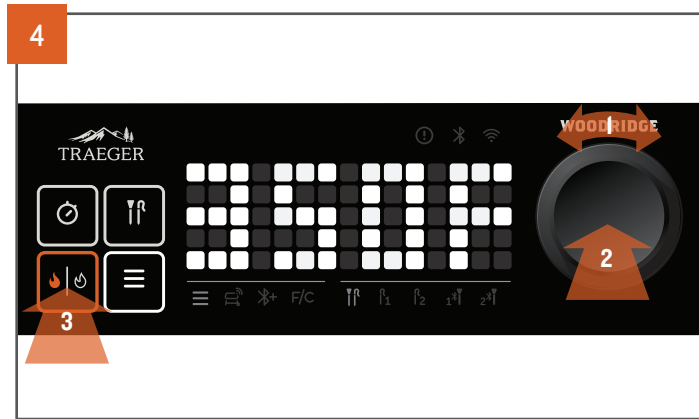

Turn the selection dial to set the grill's temperature to 350°F (177°C), then press the dial. Press the ignite/shutdown button.



PRO TIP: This seasoning process is important to ensure proper grill performance. Make sure that all internal components have been properly installed prior to this seasoning cycle and that there is no food on the grill grates during this cycle.



The grill temperature will display as it increases to the set temperature.

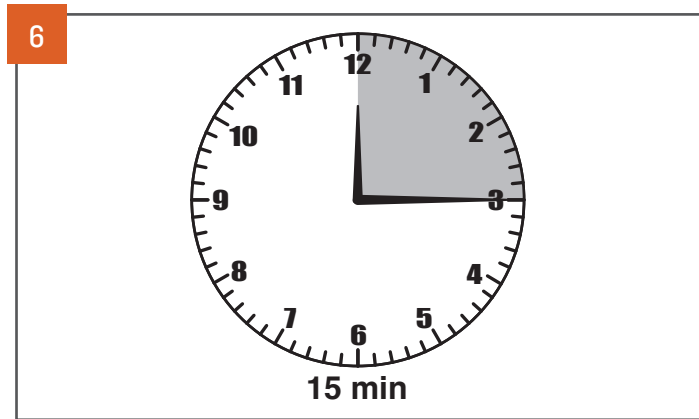

Once the grill has reached 350°F (177°C), let it run for 15 minutes. While the grill is seasoning, you may see dark or excessive smoke and ash; this is normal and will not be as significant on future startups.



After 15 minutes at 350°F (177°C), increase the temperature to 500°F (260°C).

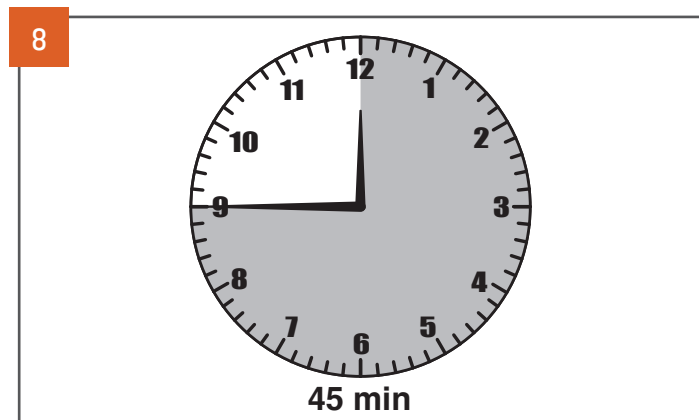

Once the grill has reached 500°F (260°C), let it run for another 45 minutes to ensure seasoning is completed properly.

NOTE: Getting to first-time seasoning temperature may take up to an hour.



ONBOARDING PART 2: SEASONING YOUR GRILL CONTINUED

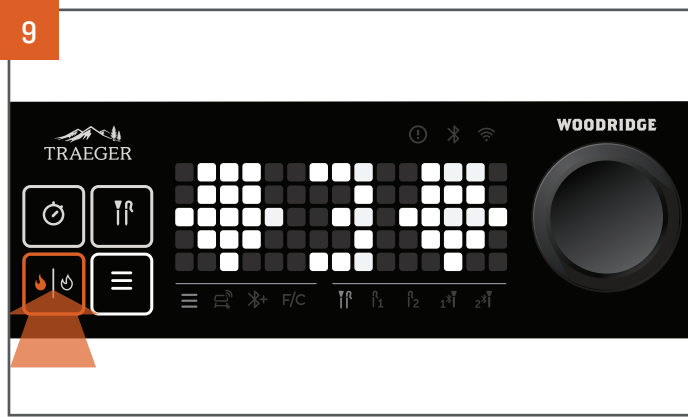

After 45 minutes at 500°F (260°C), shut down the grill and let the shutdown cycle complete. To shut down your grill, press and hold the ignite/shutdown button or the selection dial for three seconds until the display shows the shutdown animation.

NOTE: Always initiate a shutdown cycle after each and every cook.



A countdown timer begins while the grill is shutting down. You will hear the fan continue to run.

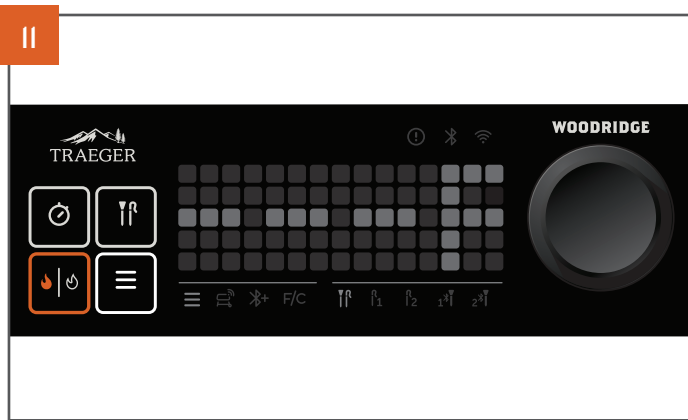

Once this countdown is complete, the shutdown cycle is complete.

NOTE: It is normal to observe ash on the drip tray and/or grill grates after seasoning. Simply wipe away ash on grill grates prior to your first cook.

MAINTAINING YOUR GRILL

Do you love bacon, sausage, and brisket? We do, too, but after cooking these fattier cuts, it's more important than ever to remove grease from the grill. Fortunately, it's easy to do. When the grill has cooled to a warm temperature, scrape grill grates and wipe up this grease from the drip tray (be careful not to burn yourself). This will ensure that everything runs smoothly the next time you fire up, especially if you plan to cook something hot and fast!

1. BEFORE EACH COOK:

Remove any buildup from the drip tray, or replace the drip tray liner. Check the EZ-Clean Grease & Ash Keg, empty if full, and replace with a new EZ-Clean Grease & Ash Keg liner.



PRO TIP: Cover the drip tray only with genuine Traeger branded Drip Tray Liners. Using foil or other materials will significantly impact the performance of the grill and could damage the drip tray or grill.

2. AFTER EACH COOK:

After shutdown, remove any excess food from the grates while still warm. Scrape all grease into the EZ-Clean Grease & Ash Keg. Reinstall the Ember Shield.

NOTE: When scraping out grease, do not use a metal scraper.

WARNING To avoid injury, ensure all ash is cooled before cleaning.

3. MONTHLY:

Check the firepot and remove ash in, around, and underneath. Vacuum the ash from the inside of the firepot. Scrape creosote from the backsplash and the back of the grill lid. Do a final wipe-down of the grill cavity with Traeger Grill Cleaner. Remove and clean out the grease drain chute. Remove ash by sweeping it into the EZ-Clean Grease & Ash Keg.

NOTE: When scraping out creosote, do not use a metal scraper.

4. AS NEEDED:

Replace the EZ-Clean Grease & Ash Keg liner when full.

WARNING Fire Hazard: Grease fires are most frequently caused by failing to properly maintain the grill by not cleaning the grease from the grill on a consistent basis.

WARNING Press the main power switch to OFF (0) and disconnect the power cord before initiating any of the maintenance below.

